

TOYO-INTL®

TIAN JIN TOYO LIFTING MACHINE MANUFACTURE CO.,LTD

CHINA ADD:NO.4668 Xinbei Road
Tang Gu Town The New Area Of Tian
Jin 300457 .P.R.CHINA

JAPAN ADD:I-49-12 Yachimata,
Yachimata-shi, Chiba 289-1143,
Japan

TEL/FAX: +86-18902171166(Whatsapp)
+86-022 59892153

EMAIL:SALES@TOYOHOISTING.COM
WEB:HTTP://WWW.TOYO-INTL.NET



Please scan the code to learn more

Regional distributor

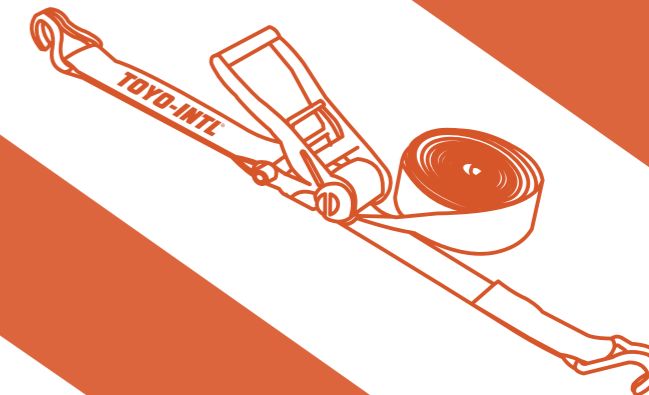
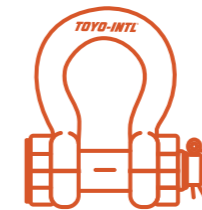

TOYO-INTL®

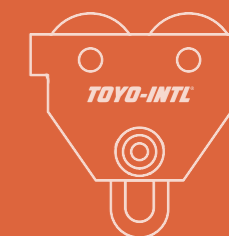
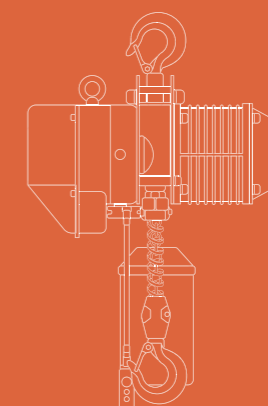

COMPANY PROFILE

The TOYO-INTL brand is jointly invested by TIANJIN TOYO LIFTING MACHINE MANUFACTURING CO., LTD. and TOYOINTL LIFTING JAPAN CO., LTD. Products by China and Japan professional design team jointly designed and developed, committed to creating excellent quality lifting tools. We strictly follow international standards and industry norms, select high-quality raw materials, and adopt advanced Japanese production technology and manufacturing equipment to ensure that every product has excellent performance and reliable quality.

All products, fittings and assemblies are factory-tested and inspected according to stringent international standards. Our QC department promises that every materials are inspected before assembling and 100% products are tested and inspected before delivery. All our test machine is from Japan high quality equipment.

We have a strong R&D Design ability to ensure that you are getting the latest products produced with the most advanced and cost-effective technologies.

Our products have been exported to many countries and regions throughout the world in Europe, North America, South America, Australia, South-eastern Asia, South Africa etc.

Our products get ISO、CE、GS certified. All products supplied and installed are warranted against defects inmerchantable quality and workmanship.

SERVICE&QUALITY CONTROL

Mission statement

1. To our customer.

Customer first, correctly understand customer intentions, quickly give answers, and do a good job of efficient service.

2. to our team.

Unity and friendship, true integrity, mutual help.

3. to our competitor.

Mutual respect, fair competition, and common development.

The company is committed to achieving high customer satisfaction through the four(4) pillars of our quality system :

CUSTOMER SATISFACTION:

We believe the only way to guarantee customer satisfaction is to ensure process consistency. Today's quality product supply ensures tomorrow's repeat order. We know and understand the concept that excellence requires continuous improvement.















INTERNAL AUDITS:

Our management representative and internal quality auditors plan and carry out auditing activities to ensure that the quality system is relevant and effective, internal and external audit reports will be objectively analyzed and where applicable, have recommendations submitted for the continuous improvement of the quality management system.

QUALITY:

We work closely with our steel suppliers to ensure that the raw material meets our stringent specification.



	CHAIN HOIST	←————→	01 - 10
	LEVER HOIST	←————→	11 - 16
	STEEL JACK AND TIRFOR	←————→	17 - 18
	ELECTRIC HOIST	←————→	19 - 36
	TEXTILE SLING	←————→	37 - 40
	TROLLEY SERIES	←————→	41 - 44
	LIFTING CLAMP	←————→	45 - 52
	MAGNET LIFTER	←————→	53 - 56
	CHAIN SLING	←————→	57 - 62
	HOOK & LINK	←————→	63 - 66
	CRANE SCALE	←————→	67 - 68
	LIFTING JACK	←————→	69- 75
	PULLER & WINCH	←————→	76 - 77
	PALLET TRUCK	←————→	78 - 78
	RIGGING HARDWARE	←————→	79 - 90



CHAIN BLOCK

- All structural parts made of high quality steel.
- Alloy steel hooks.
- Gear made of alloy steel.
- Strong nut.
- Hollow structure increases strength.
- Casting safety latches.
- All Major components are strictly heat-treated.
- Load chain made by GERMAN machine.
- Emboss logo.
- Galvanized plate.

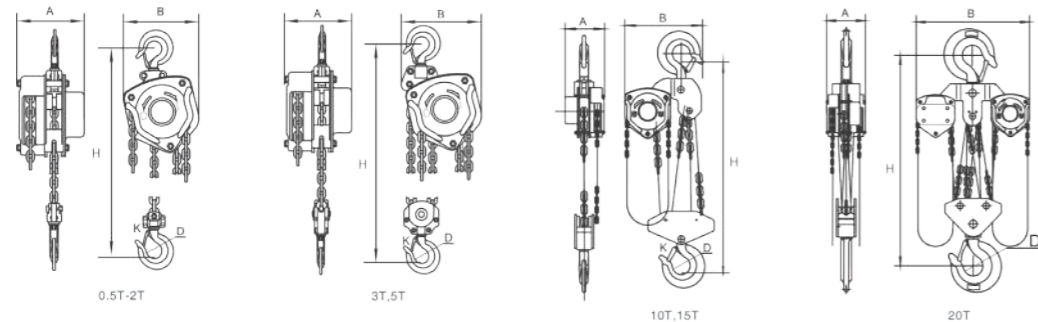

Model :VT

SPECIFICATION

Model	Capacity (t)	Standard Lift (m)	Running test(t)	Effort required to lift max load(n)	No. of falls of load chain	Load chain diameter(mm)	Dimensions(mm)				Net weight (kg)	Packing (L*W*H)(cm)
							A	B	D	H		
VT-0.5T	0.5	2.5	0.5	350	1	5	126	145	28	285	8.4	22*14*15
VT-1T	1	2.5	1	330	1	6.3	151	159	32	315	12	25*19*16
VT-1.5T	1.5	2.5	1.5	348	1	7.1	151	178	36	340	16.2	33*24*16
VT-2T	2	3	2	365	1	8	183	205	36	380	20	33*24*19
VT-3T	3	3	3	360	2	7.1	151	208	46	475	24	34.5*24*16
VT-5T	5	3	5	410	2	9	183	264	46	600	41	40*30*19
VT-10T	10	3	10	410	4	9	188	398	57	720	79	48*42*18.5
VT-15T	15	3	15	435	6	9	190	580	75	870	120	69*56*20
VT-20T	20	3	20	435*2	8	9	192	630	82	890	193	78*68*20
VT-30T	30	3	30	435*2	12	9	330	670	106	1000	220	85*67*30
VT-50T	50	3	50	435*2	22	9	410	900	130	1950	1092	110*100*130

FEATURES



DOUBLE PAWL SPRING MECHANISM TO FURTHER INCREASE SAFETY
In case on pawl spring is damaged, the other maintains functions. This mechanism further increases safety.

Special heat treated hook, will never broken even under overload situation.

Embossed Logo and Capacity for permanent identification.

High strength alloy steel gears with special heat treatment to increase the strength.

Special pitch length, match hand wheel very well saving pulling force and no block during chain moving.

Pin type chain stop, easy disassembled Casting chain stop is optional.

High strength G80 Alloy Steel Load Chain.

Special hook tip design, prevent latch slip out of hook, more safety.

LOAD CHAIN GUIDE MECHANISM
Machined load wheel providing better match. Chain guide mechanism in flanged load sheave and guide roller facilitate smooth movement of load chain.



CHAIN BLOCK

- Experience exceptional durability thanks to all-steel construction featuring rugged gear case enclosure and hand wheel cover.
- Enjoy increased lifting height thanks to low headroom.
- Compact design results in lightweight and easy portability.
- Minimize manual effort thanks to efficient drive train.
- Standard slip clutch device prevents the hoist from being used to lift damaging loads beyond rated capacity.
- Double pawl springs provide redundancy for reliable operation of brake mechanism.
- Get reliable braking with double enclosed brake cover that keeps out dust, rain, and dirt.



Model :VD

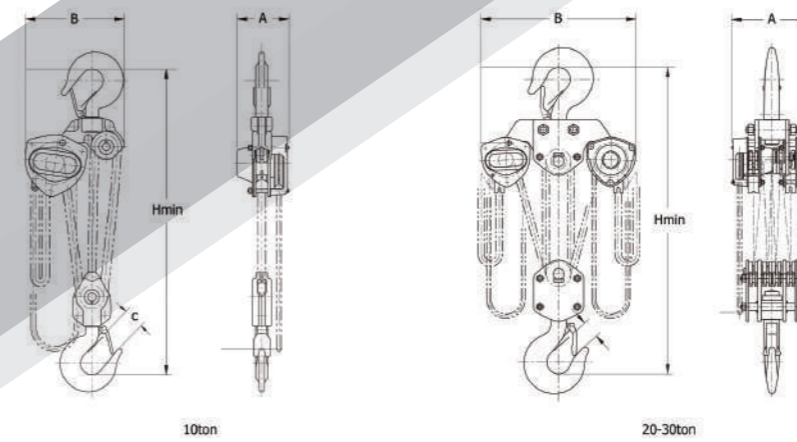
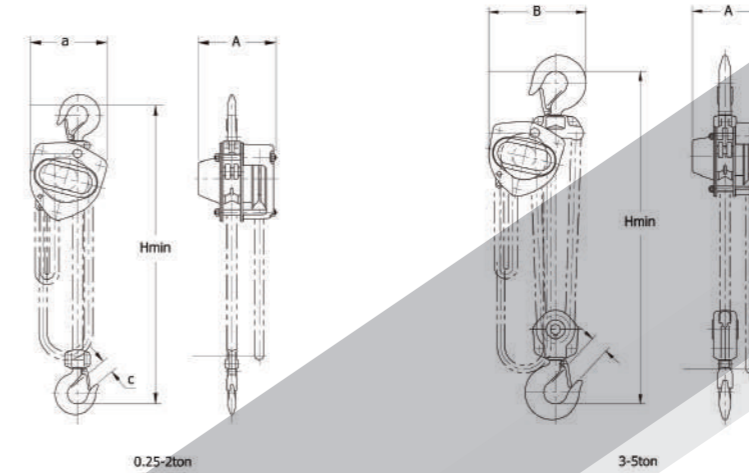

Model :VD



Tail ring holder



Overload Protection Device



Casting guide wheel



Sealed roller bearings



G80 Chain



Safety Hook

Specifications:

Model	VD-0.25T	VD-0.5T(MINI)	VD-0.5T	VD-1T	VD-1.5T	VD-2T	VD-3TS	VD-3T	VD-5T	VD-10T	VD-20T
W.L.L(kg)	250	500	500	1000	1500	2000	3000	3000	5000	10000	20000
Lift(m)	2.5	2	2.5	2.5	2.5	2.5	3	3	3	3	3
Load Chain	Falls	1	1	1	1	1	1	2	2	4	8
	Size	4x12	5x15	5x15	6x18	7.1x21	8x24	10x30	7.1x21	9x27	9x27
Hand Force(N)	220	250	240	250	265	335	363	265	360	380	380x2
N.W(kg)	3.8	6.5	11	12.5	17.8	19.5	29	23.5	41.3	78.5	193
Dimensions	A(mm)	102	125	132	151	173	176	173	189	189	189
	B(mm)	106	116	148	172	196	210	230	226	280	463
	C(mm)	21	30	28	32	36	36	46	46	46	57
	Hmin(mm)	260	310	345	376	442	470	565	490	688	765
Packing Size(cm)	20x15x12	22x15x15	24x19x18	28x21x21	34x26x20	34x26x20	41x32x24	34x26x20	41x32x24	48x42x18.5	78x68x20



CHAIN BLOCK

- Compact Design, Low Headroom - Wide Usage.
- High Precision CNC Gears.
- Impact Resistance Gear Cover.
- High Endurance Rollers on Load Sprocket.
- Double Pawl Brake System.
- Dust Cover on Brake System.
- Engineering Optimized Hand Chain Wheel Cover- Preventing Hand Chain Stack in Fast Operation.
- High Precision Double CNC Load Chain Guides.
- Zinc Plated Stay Bolts, Side Plates & Load Chain Guides.
- Robust - Higher than 1500 cycles EN 13157 Endurance Testing



Model :VJ

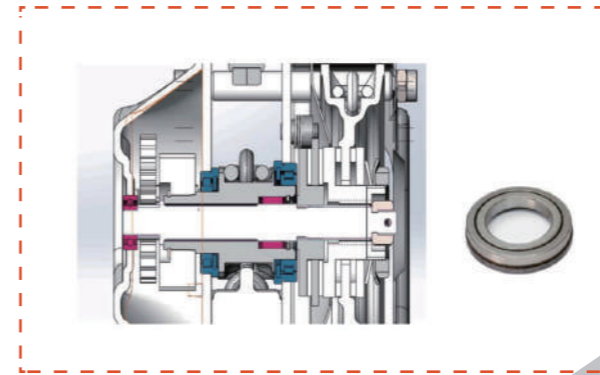

- 01.4 Caged Bearings Premium Upgrading.
- 02.Thrust Bearings on Bottom Hook.
- 03.Zinc Plated Load Chain.

- 4.Over Load Protection (OLP)Direct Shifting to non-OLP Version.
- 5.Type-A Gear Cover Apperance Option.
- 6.High Precision Caged Roller Bearings.
- 7.Zinc Plated Cast Safety Latch.

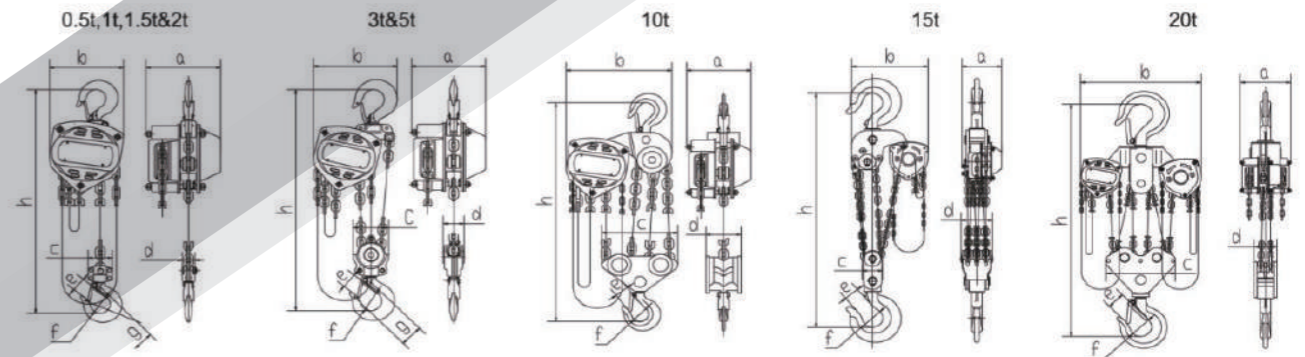

Specifications:

Capacity (tonnes)	0.25	0.5	1	1.5	2	2	3	5	10	15	20
Purchasing Ref.	VJ025	VJ050	VJ100	VJ150	VJ20	VJ200S	VJ300	VJ500	VJ1000	VJ1500	VJ2000
No. of Falls	1	1	1	1	2	1	2	2	4	6	8
Load Chain (mm)	4 x 12	5 x 15	6 x 18	8 x 24	6 x 18	8 x 24	8 x 24	10 x 30	10 x 30	10 x 30	10 x 30
Pull to Rated Load (N)	200	240	370	490	425	440	490	510	470	470	470x2
Proof Load (tonnes)	0.38	0.75	1.5	2.25	3.0	3.0	4.5	7.5	15	22.5	30
Hand Chain (mm)	3 x 15 x 10.5			5 x 25 x 17							
Standard Lift (m)	3	3	3	3	3	3	3	3	5	5	5
Net Weight (kg)	4.35	7.8	11.1	15.8	15.14	16.8	24.2	39.8	89.7	91.1	197
Extra Wt. per m (kg)	0.37	1.38	1.62	2.23	3.24	2.23	3.62	5.18	9.52	13.86	19.03
Dimensions	a (mm)	102	125	134	151	134	157	157	180	180	210
	b (mm)	106	130	155	173	185	185	235	262	365	406
	c (mm)	29.5	43	51	64	80	64	100	126	260	110
	d (mm)	21	25	30	34	55	34	56	74	98	168
	e (mm)	27	27	33	33.5	37	37	43.5	51	64	80
	f (mm)	32	32	40	42	46	46	52	60	85	100
	g (mm)	35	35	45	47	52	52	62.5	79	-	-
	h (mm)	250	280	306	368	450	445	520	600	760	1,000



Gear Cover



Wheel Cover



Chain Guides



Zinc Plated Stay Bolts



Load sprocket



ALUMINUM HAND CHAIN HOIST

- Suspension devices and load-bearing hooks are made of anti-aging and high strength alloy steel. In case of overloading, deformation will occur first and not suddenly break.
- The hook is equipped with a secure safety latch which can rotate 360 degree freely.
- Enclosed design protects internal components.
- Excellence in engineering led to the development of the world's smallest industrial hoist—the MNAC. This uniquely compact and lightweight manual hoist is the perfect solution for light loads in high or difficult-to-reach places.
- The MNAC comes standard with an advanced design load limiter that prevents the hoist from being used to lift damaging loads beyond rated capacity.
- The MNAC gives you a unique combination of portability and extreme durability with its lightweight, die-cast aluminum housing. Take this little hoist with you everywhere for the small jobs that require big dependability.



Model :MNAC

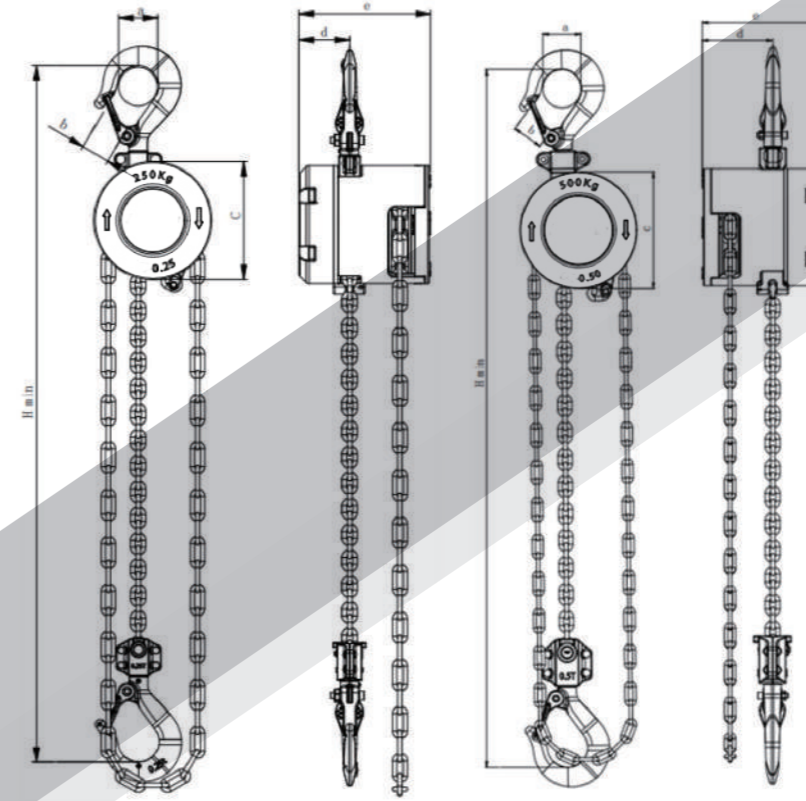

0.25t

0.5t

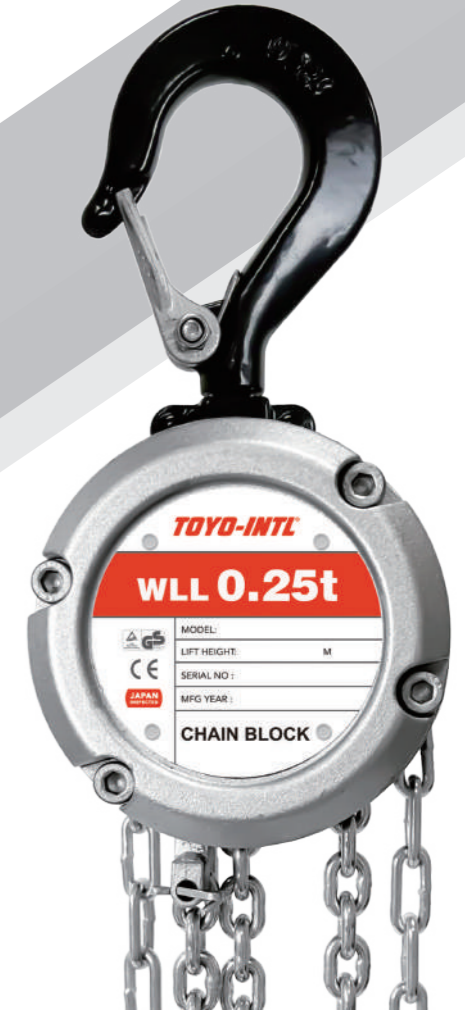

Model:MNAC



Safety Hook



light weight aluminum shell



G80 Chain

Specifications:

Model	unit	MNAC025	MNAC050
Standard lifting height	(m)	2.5	2.5
Chain fall		1	1
Full load force	(N)	210	230
Test load	(kg)	375	750
Load chain size	(mm)	3.2X9	4X12
Hand chain size	(mm)	3X16.5	3X16.5
Net weight	(kg)	2.4	3.9
Packing weight	(kg)	2.7	4.2
Packing dimensions	(cm)	18x11x11	23.5x13.5x12
Weight of per lift meter	(kg/m)	0.23	0.341
Hand chain weight per lift meter	(kg/m)	0.34	0.34
Dimensions (mm)	a	27	34
	b	20	22
	c	82	104
	d	45	63
	e	102	101
	Hmin	233	307



CHAIN BLOCK

- Light weight robust construction;
- Low effort to lift maximum load;
- Fully forged hooks;
- Fully machines lift wheel;
- ISO high grade alloy chain;
- Zinc plated hand chain as standard;
- Double cover protection;
- Durable baked enamel paint protection;
- Overload protection device available upon request.

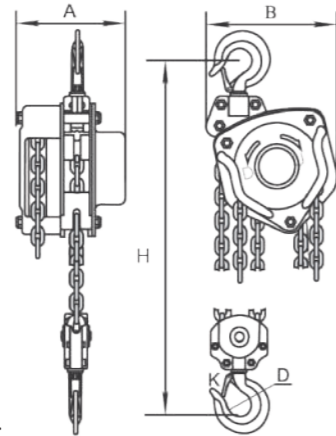

Overload Protection Device



Sealed Roller Bearings



Ratchet disk



Unique Curled Edge

Model :VB

SPECIFICATION

Model	VB-0.5	VB-1	VB-1.5	VB-2	VB-3	VB-5	VB-10	VB-20	VB-30	VB-50	
Capacity	load(t)	0.5	1	1.5	2	3	5	10	20	30	50
Standard	lift(m)	2.5	2.5	2.5	3	3	3	3	3	3	3
Running	testload(kn)	7.5	15	22.5	3	4.5	7.5	15	30	45	70
Effort required to lift max.load(N)		200(20.5)	320(32.5)	360(36.5)	365(37)	385(39)	435(44.3)	435(44.3)	435x2(44.3x2)	435x2(44.3x2)	435x2(44.3x2)
Load chain diameter number of falls(mm)		6.0x1	6.0x1	8.0x1	8.0x1	8.0x2	10.0x2	10.0x4	10.0x8	10.0x12	10.0x22
The distance of hand chain pulling when lifting height go up 1meter (mm)		32	40	72	72	144	158	316	636x2	948x2	1738x2
Net weight(kg)		8.4	11	16.2	18.5	25.6	42.8	79.5	193	220	1092
Extra weight meter of extra lift(kg)		1.7	1.7	2.3	2.3	3.7	5.6	9.7	19.4	26.4	48.4
Dimensions(mm)	A	131	140	161	161	161	186	207	215	350	406
	B	127	158	187	187	210	253	398	650	680	962
	C	270	317	399	414	465	636	798	890	1380	2578
	D	35	40	45	50	58	64	85	110	110	170
	K	30	34	38	41	48	52	64	85	85	130
Packing measurement (L*W*H)(cm)		22x15x19.5	23x18x19.5	28x21x24	28x21x24	32x21x26	40x21x21	64x21x21	64x38x64	72x50x68	110x100x130

CHAIN HOIST

- Superior Grade 100 load chain-WAFIOS link, Din standard.
- Forged and heat treated load hooks with batch traceability and stretchindicators.
- Double pawls supporting fail-safe brake mechanism Even if by any chance one of the two pawls becomes unserviceable, the other will still remain operative, and the brake system remains secure.
- Asbestos free brake linings.
- Forged safety latch with manufacture.
- Individually proof load tested to 1.5xWLL with individual serial number. Light weight yet durable Steel frame construction is rugged yet light weight and easy to handle.

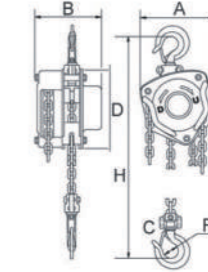

Model :CK

SPECIFICATION

Product Code	Capacity (t)	Standard Lift(m)	Test Load (t)	Pulling Efforts (kg)	Chain Fall No.	Load Chain Dia.(mm)	Dimensions(mm)				Net weight (kg)
							A	B	C	D	
CK005	0.5	3.0	0.75	22	1	6	125	111	24	134	8.1
CK010	1.0	3.0	1.50	31	1	6	147	126	28	154	11.2
CK015	1.5	3.0	2.25	35	1	8	183	141	34	192	15.3
CK020	2.0	3.0	3.00	30	1	8	215	163	38	224	17.1
CK030	3.0	3.0	4.50	35	2	8	183	141	38	192	18.0
CK050	5.0	3.0	7.50	39	2	10	215	163	48	224	21.7
CK100	10.0	3.0	12.50	41	4	10	360	163	64	224	65.2
CK200	20.0	5.0	25.00	41x2	8	10	585	191	82	224	194.0
CK300	30.0	5.0	37.50	47x2	12	10	705	485	75	285	458.0



LEVER HOIST

- All steel construction.
- Compact design.
- Double pawl braking system.
- Fully forged hooks.
- Long - lasting powder coating protection.
- High standard G80 load chain (black or galvanized).

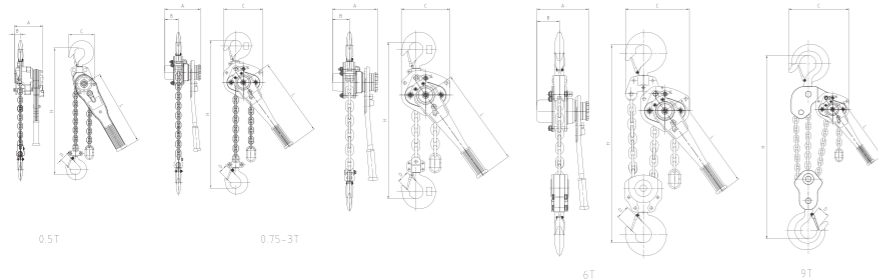

Model :VL



LEVER HOIST

- The adoption of low-alloy structural steel plate, safe, reliable and durable.
- G80 high strength load chain, high safety factor and long service life.
- Steady rotation, high efficiency, small lever force.
- Products certified by CE and GS.
- Double pawl keep safe and reliable.
- The products have been widely used in nuclear power, thermal power transmission and transmission etc.
- Optional overload protection.

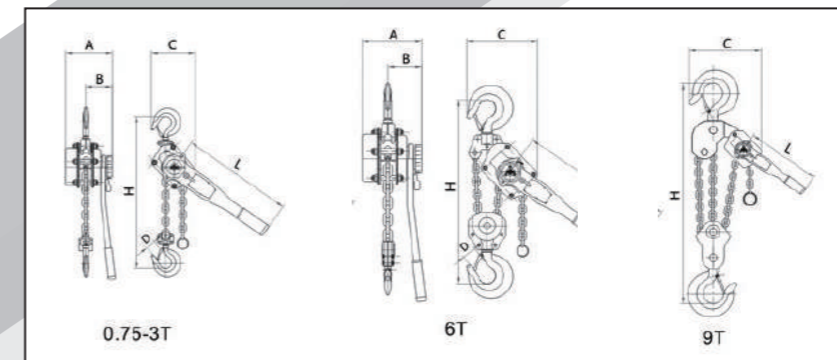

Model :VAJ

SPECIFICATION

MODEL	Load Capacity(t)	Standard Lift(m)	Running Test(t)	Effort required to lift max load (N)	Load Chain		Lifting Motor						Net Weight (kg)	Packing (L*W*H)(cm)	Extra weight meter of extra lift (kg)
					Chain Fall Number	Diameter (mm)	H	A	B	C	D	L			
VL0.5	0.5	1.5	0.75	330	1	5	270	105	24	85	31	265	3.5	33.5x12.5x9	0.55
VL0.75	0.75	1.5	1.125	230	1	6.3	303	150	55	128	32	254	6.6	34x12x17	0.88
VL1	1	1.5	1.5	250	1	6.3	303	150	55	128	32	254	6.6	34x12x17	0.88
VL1.5	1.5	1.5	2.25	295	1	7.1	365	165	64	149	36	366	11	45x16x18	1.12
VL2	2	1.5	3	315	1	7.1	365	165	64	149	36	366	11	45x16x18	1.12
VL3	3	1.5	4.5	414	1	9	485	195	85	182	46	366	17	47x20x21	1.78
VL6	6	1.5	9	430	2	9	600	195	85	240	46	366	27.5	47x20x21	3.74
VL9	9	1.5	13.5	430	3	9	700	195	85	335	57	366	47	62x48.5x26	5.81

SPECIFICATIONS

Model	Capacity (t)	Standard Lift (m)	Running test(t)	Effort required to lift max load(n)	No.of falls of load chain	Load chain diameter(mm)	Dimensions(mm)						Net weight (kg)	Packing (L*W*H)(cm)
							A	B	C	D	L	H		
VAJ-0.5T	0.5	1.5	0.75	140	1	5	102	80	95	32	290	320	3.5	33.5*12.5*9
VAJ-0.75T	0.75	1.5	1.125	140	1	6	148	87.5	135	32	290	320	7	37*14*17
VAJ-1T	1	1.5	1.5	140	1	6	148	88	135	32	290	320	7.5	37*14*17
VAJ-1.5T	1.5	1.5	2.25	240	1	8	175	102	157	36	415	380	11	52*14*18
VAJ-2T	2	1.5	3	240	1	8	176	102	155	36	415	380	11.5	52*14*18
VAJ-3T	3	1.5	4.5	320	1	10	195	109	210	45	415	480	19	55*16*21
VAJ-5T	5	1.5	7.5	340	2	10	195	109	253	45	415	600	32	55*16*21
VAJ-9T	9	1.5	11.25	360	3	10	195	109	319	57	415	700	47	62*48.5*26



LEVER HOIST

- Suspension devices and load-bearing hooks are made of anti-aging and high strength alloy steel. In case of over-loading, the deformation will take place first and not suddenly break.
- The hook is equipped with a secure safety latch, which can rotate 360 degree freely.
- The ergonomic handle makes the hoist easy to operate.
- The enclosed design protects the internals from contamination.
- All components of the disc load brake are made of high-quality materials and are corrosion-resistant.
- The enclosed design protects the internals from contamination.
- The chain block is made of aluminum alloy and is not easy to rust.



G80 load chain



Aluminum alloy hook



Guide roller system



Flexible handle



Model L:ALB



MINI LEVER HOIST

HSH Lever Hoist is an efficient and versatile lifting tool. Superior Grade 100load chain-chrome plated. Forged and heat treated load hooks with batch trace ability and stretch indicators. Double pawls brake system.

MINI HSH Specification				
Capacity(kg)	250	500	750	1500
Standard lift(m)	1.5	1.5	1.5	1.5
Test load(kg)	375	750	1125	2250
Hand-pull to lift(n)	250	250	200	240
Extra weight for one meter chain added(kg/m)	0.346	0.346	0.541	1.1
Load chain(dia.Xpitch)(mm)	φ4x12	φ4x12	φ5x15	φ7x21
Dimensions(mm)	A	62	70	92
	B	158	194	230
	C	156	156	232
	D	30	35	38
Dimensions(mm)	E	84	105	136
	F	240	300	350
	G	96	116	128
	H	77	79	84
N.W./G.W.(kg)	2.15/2.2	3.1/3.2	4.75/4.85	7.6/8

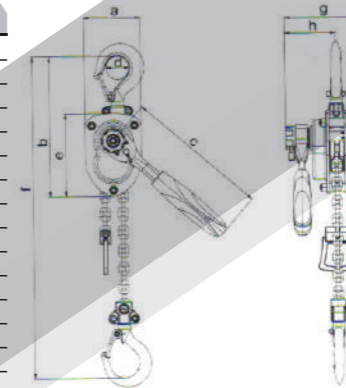

Model L:HSH

ALB ALUMINIUM LEVER BLOCK

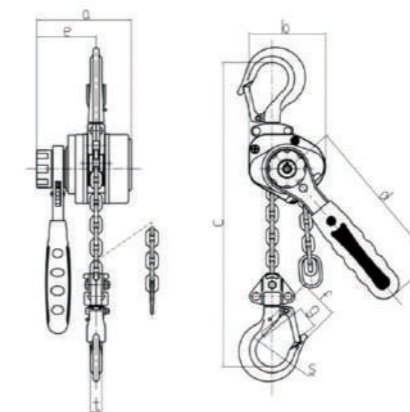

Specifications:

Model	Capacity (t)	Standard lift (m)	Running test load (t)	No. of falls of load chain	Load chain diameter (mm)	Dimension(mm)										Net weight (kg)
						A	B	C	D	E	F	G	S	T		
ALB 0.25T	0.25	1	0.375	1	3.2	87	68	200	145	55.5	35.5	21	32	11	1.5	
ALB 0.5T	0.5	1.5	0.75	1	4.3	100.5	81	250	160	62.5	42	24.5	34.5	12	2.5	



LEVER HOIST



Model :LBP

- All-steel construction featuring, rugged gear case and hand wheel, exceptional durability.
- Reinforce double pawl brake system and lager dia. pawl springs ensure reliable brake.
- Unique curling design-This leature enables the hand chain to successlully feed directly into the wheel sprocket from many directions and angles.
- G80 heat treated alloy load chain.
- Forged alloy Steel Hooks-Industrial rated hooks rotate 360 degrees for easy rigging. Hooks slowly stretch to indicate an overload situation increasing jobsite safety.
- Sealed roller bearings-Greatly improving performance and serve life of the product.
- Certification-Load tested to 150% of capacity with certificate.

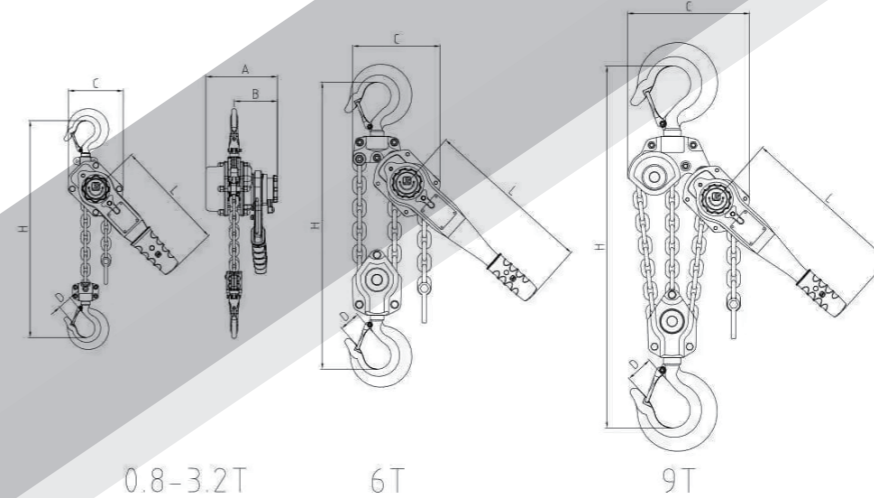
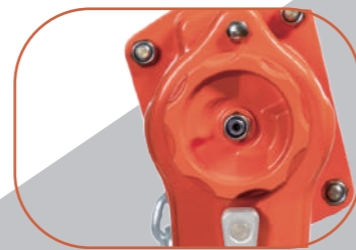

Model :LBG

Technical Parameters

LBG(LBP) Specifications Sheet														
Model	W.L.L(t)	LIFT(m)	Proof Load(t)	Lever Force kg(n) (lbs)	Load Chain		Dimensions(mm)						N.W. (kg)	Additional Weight Per Lift(kg)
					Falls	Size	H	A	B	C	D	L		
LBG(LBP) 0.8	0.8	1.5	1.2	22(215)(48)	1	5.6x15.7	300	150	100	119	24	245	6.3	0.7
LBG(LBP) 1	1	1.5	1.5	30(294)(66)	1	5.6x15.7	300	150	100	119	24	245	6.3	0.7
LBG(LBP) 1.6	1.6	1.5	2.4	31(304)(68)	1	7.1x19.9	350	168	104	126	32	265	8.5	1.1
LBG(LBP) 3.2	3.2	1.5	4.8	38(372)(84)	1	10x28	395	201	118	159	35	415	14.2	2.3
LBG(LBP) 6.3	6.3	1.5	9.5	39(382)(86)	2	10x28	540	201	118	218	44	415	26	4.6
LBG(LBP) 9	9	1.5	13.5	40(392)(88)	3	10x28	680	201	118	298	60	415	40	6.9



MECHANICAL STEEL JACK



SAFETY RACTHET CRANK

One - sided braking effect and the load is held safety at every height with folding handle.



SAFETY RAIL JACK

High stability on uneven ground is ensured by the extra large floor plate.

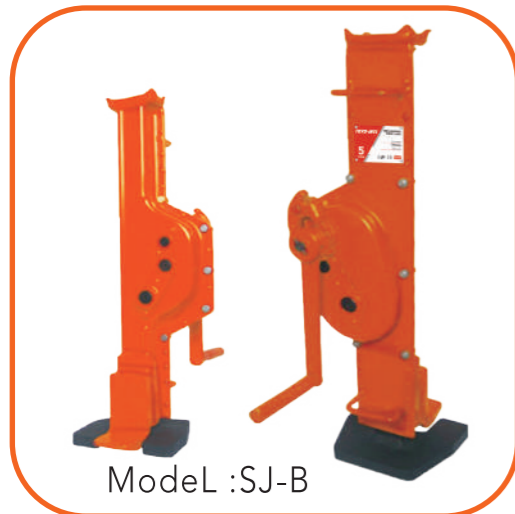

Model :SJ-B



Model :SJ-A



Model	Safe Working Load (t)	Height of Load (mm)	Lifting Height (mm)	Height of Claw in Lowest Position (mm)	Net Weight (kg)
SJ-A 1.5	1.5	725	300	70	13
SJ-A 3	3.0	725	300	75	20
SJ-A 5	5.0	725	350	70	27
SJ-A 10	10	800	350	90	47
SJ-A 16	16	950	400	95	64
SJ-A 20	20	950	400	95	73
SJ-B 1.5	1.5	570	300	70	11
SJ-B 3	3.0	570	300	75	18
SJ-B 5	5.0	600	300	70	22
SJ-B 10	10	650	300	80	38

WIRE ROPE PULLING HOIST (TIRFOR)

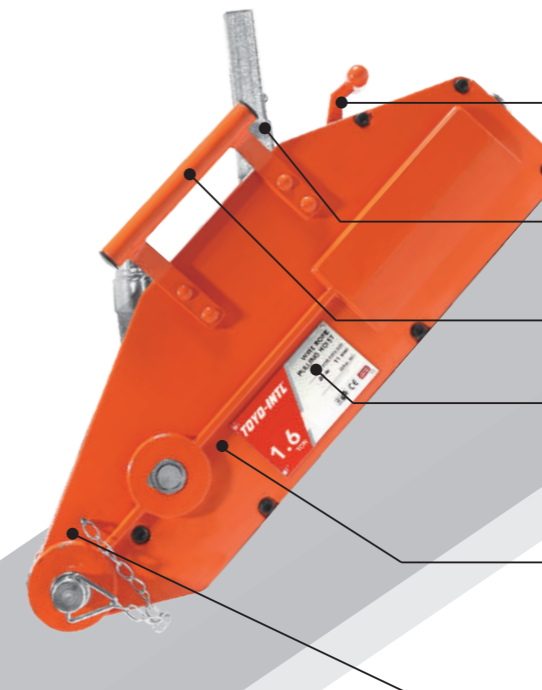

Rope clamp system

Easily disengaged with a lever allowing smooth installation of the wire rope.

Backward lever&Forward lever

Placed in tandem providing a slim design and assuring power transfer along the center.

Spares hear pins

Two spares hear pins located in the carrying handle.

Stamped serial number

for easy identification.

High strength cast aluminium alloy body

Lightweight, simple to operate,Smooth contour design with large, flat bottom surface for increased stability in horizontal as well vertical working position.

Anchor bolt

Offers numerous and versatile connection possibilities with load hooks,sling ropes and sling chains.

Model :ZNL

Galvanized steel wire rope mounted on a reel

Every rope is operationally tested to 150% of the rated capacity and issued with an individual test certificate.



Adjustable handle

For easy operation.

Item No.	ZNL Specification			
	ZNL08	ZNL16	ZNL32	ZNL54
Lifting capacity(kg)	800	1600	3200	5400
Pulling capacity(kg)	1300	2800	6000	10125
Tested to(kg)	1500	3000	6000	10125
Steel wire rope dia.(mm)	IWRC8.3	IWR11	IWRC16	IWRC20
Wire rope safety factor load capacity(kg)	5xWLL	5xWLL	5xWLL	5xWLL
Breaking strength of wire rope(kg)	5430	9680	17200	27000
Overall structure breaking strength(kg)	4xWLL	4xWLL	4xWLL	4xWLL
Safety device	Safety pins	Safety pins	Safety pins	Safety pins
Net weight wire rope (20m)	7	12	24	45.5
Net weight (without wire Rope)(kg)	6.4	12	23	54.5



EXPLOSION-PROOF CHAIN HOIST(COMBINDED)

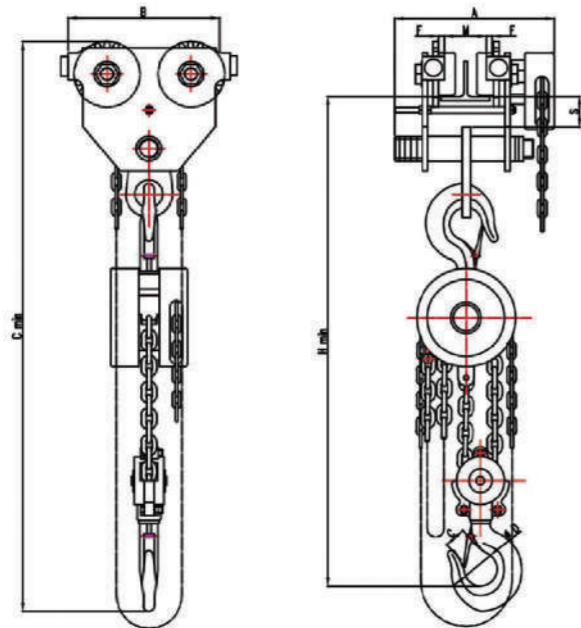

Model :GCBL



TECHNICAL PARAMETERS

MODEL	Capacity (t)	Test load (kn)	Standard Lifting height (m)	Hand pull (horizontal straight) N	Dimension(mm)					Track width(mm)	Net weight(kg)	
					B	S	Hmin	C	F		GCBL	GCBT
GCBL1	1	1.5	3	50	245	170	170	170	90-122	90-122	15	13
GCBT1	1	1.5	3	50	245	170	170	170	90-122	90-122	15	13
GCBL2	2	3	3	90	245	190	190	190	102-152	102-152	20	17
GCBT2	2	3	3	90	245	190	190	190	102-152	102-152	20	17
GCBL3	3	4.5	3	95	275	220	200	200	110-165	110-165	26	23
GCBT3	3	4.5	3	95	275	220	200	200	110-165	110-165	26	23
GCBL5	5	7.5	3	140	350	240	210	210	122-172	122-172	34	30
GCBT5	5	7.5	3	140	350	240	210	210	122-172	122-172	34	30
GCBL10	10	15	3	240	380	265	230	230	130-210	130-210	51	47
GCBT10	10	15	3	240	380	265	230	230	130-210	130-210	51	47
GCBL20	20	30	3	250	420	265	320	320	130-210	130-210	115	106
GCBT20	20	30	3	250	420	265	320	320	130-210	130-210	115	106

EXPLOSION-PROOF ELECTRIC CHAIN HOIST

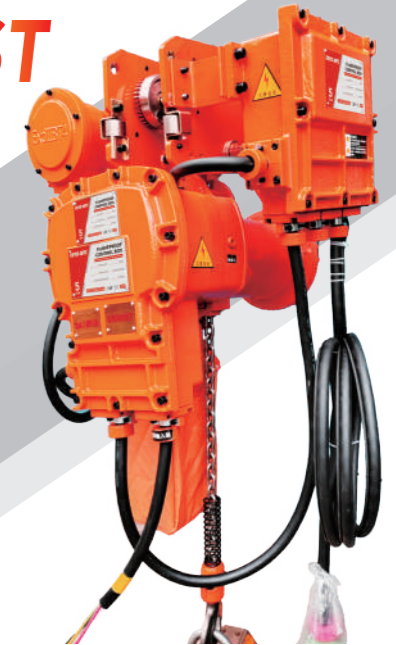
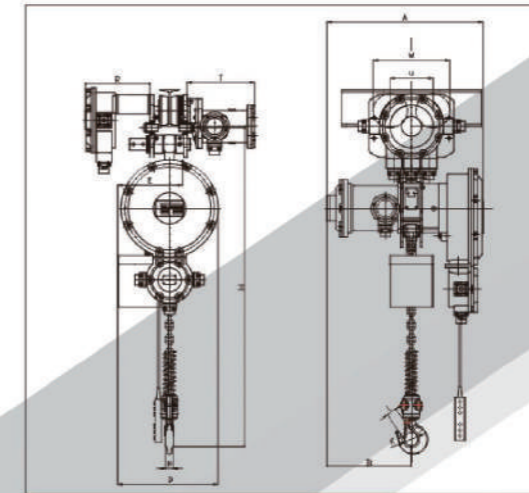

Model :HHBB

TECHNICAL PARAMETERS

Type	Lifting Motor							Operating Motor							I-Beam (mm)
	Capacity (t)	Lifting Speed (m/min)	Power (kw)	Rotation Speed (r/min)	Phases	Voltage(v)	Frequency (hz)	Power (kw)	Rotation Speed (r/min)	Operating Speed (m/min)	Phases	Voltage (v)	Frequency (hz)		
HHBB1-3	1	6.8	1.5	1440	3	220-440	50/60	0.4	1440	10-20	3	220-440	50/60	80/160	
HHBB2-3	2	6.8	3.0	1440	3	220-440	50/60	0.4	1440	10-20	3	220-440	50/60	82-160	
HHBB2-3	2	3.4	1.5	1440	3	220-440	50/60	0.4	1440	10-20	3	220-440	50/60	82-160	
HHBB3-3	3	5.4	3.0	1440	3	220-440	50/60	0.4	1440	10-20	3	220-440	50/60	100-178	
HHBB3-3	3	3.4	3.0	1440	3	220-440	50/60	0.4	1440	10-20	3	220-440	50/60	100-180	
HHBB5-3	5	2.7	3.0	1440	3	220-440	50/60	0.75	1440	10-20	3	220-440	50/60	110-170	
HHBB10-3	10	2.8	3.0*2	1440	3	220-440	50/60	0.75*2	1440	10-20	3	220-440	50/60	130-200	
HHBB15-3	15	1.9	3.0*2	1440	3	220-440	50/60	0.75*2	1440	10-20	3	220-440	50/60	140-200	
HHBB20-3	20	1.4	3.0*2	1440	3	220-440	50/60	0.75*2	1440	10-20	3	220-440	50/60	140-200	
HHBB25-3	25	1.1	3.0*2	1440	3	220-440	50/60	0.75*2	1440	10-20	3	220-440	50/60	150-220	
HHBB30-3	30	0.9	3.0*2	1440	3	220-440	50/60	0.75*2	1440	10-20	3	220-440	50/60	150-220	
HHBB35-3	35	0.7	3.0*2	1440	3	220-440	50/60	/	/	/	/	/	/	/	

Type	Capacity (t)	Unit(mm)											Chain
		H	A	B	D	E	K	L	N	M	J	Q	
HHBB1-3	1	600	657	377	300	176	Φ40	31	24	/	/	/	Φ 7.1
HHBB2-3	2	800	745	397	430	265	Φ49	35	30	/	/	/	Φ 10.0
HHBB2-3	2	750	654	377	300	230	Φ49	35	30	/	/	/	Φ 7.1
HHBB3-3	3	845	654	397	430	265	Φ59	42	35	/	/	/	Φ 11.2
HHBB3-3	3	950	745	397	430	320	Φ59	42	35	/	/	/	Φ 10.0
HHBB5-3	5	1030	745	397	430	325	Φ60	45	43	/	/	/	Φ 11.2
HHBB10-3	10	1400	794	397	890	445	Φ90	70	50	/	/	/	Φ 11.2
HHBB15-3	15	1360	794	397	1030	/	Φ110	80	85	88	Φ 70	520	Φ 11.2
HHBB20-3	20	1250	794	397	1220	/	Φ110	80	85	88	Φ 70	/	Φ 11.2
HHBB25-3	25	1700	794	397	1315	/	Φ140	100	95	96	Φ 80	/	Φ 11.2
HHBB30-3	30	1640	914	457	1380	/	Φ140	100	95	300	Φ 80	/	Φ 11.2
HHBB35-3	35	1890	914	457	1600	/	Φ140	140	135	300	/	/	Φ 11.2



ELECTRIC HOIST WITH TROLLEY



- INVERTER ADVANTAGE:**
 Good protection for the motor, could extend the motor life, start smooth, so that the motor heat and noise are less than before.
- DOUBLE SPEED ADVANTAGE:**
 1. With double speed is the latest generation setting, for slow speed could be control the speed based on the actual use of customer requirements.
 2. The hoist with double speed is mainly used in the precise controlling the lifting height, to ensure accurate positioning of the lifting objects.
- SIDE MAGNETIC BRAKING DEVICE:**
 This device shall realize the instant brake in case of the power dump.
- CHAIN BAG:** It shall be light, handsome and durable.

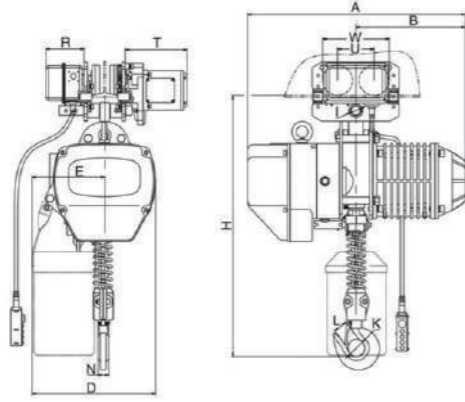

TECHNICAL PARAMETERS

Product Code	Capacity (t)	Lifting Height (m)	Lifting Speed (m/min)	Power (kw)	Rotation Speed (r/min)	Phases	Lifting Motor Voltage(v)	Frequency (hz)	Power (kw)	Operating Rotation Speed (r/min)	Motor Operating Speed (m/min)	Phases	Voltage (v)	Frequency (hz)	I-Beam (mm)
HHBD 0101	1	3/9	6.6	1.5	1440	3	220-440	50/60	0.4	1440	11/21	3	220-440	50/60	58-153
HHBD 0151	1.5	3/9	8.8	3.0	1440	3	220-440	50/60	0.4	1440	11/21	3	220-440	50/60	82-178
HHBD 0201	2	3/9	6.6	3.0	1440	3	220-440	50/60	0.4	1440	11/21	3	220-440	50/60	82-178
HHBD 0202	2	3/9	3.3	1.5	1440	3	220-440	50/60	0.4	1440	11/21	3	220-440	50/60	82-178
HHBD 0251	2.5	3/9	5.4	3.0	1440	3	220-440	50/60	0.75	1440	11/21	3	220-440	50/60	100-178
HHBD 0301	3	3/9	5.4	3.0	1440	3	220-440	50/60	0.75	1440	11/21	3	220-440	50/60	100-178
HHBD 0302	3	3/9	4.4	3.0	1440	3	220-440	50/60	0.75	1440	11/21	3	220-440	50/60	100-178
HHBD 0303	3	3/9	2.2	1.5	1440	3	220-440	50/60	0.75	1440	11/21	3	220-440	50/60	100-178
HHBD 0502	5	3/9	2.7	3.0	1440	3	220-440	50/60	0.75	1440	11/21	3	220-440	50/60	100-178
HHBD 1004	10	3/9	2.7	3.0	1440	3	220-440	50/60	0.75	1440	11/21	3	220-440	50/60	150-220

ELECTRIC CHAIN HOIST HHBD

- SHELL:** Light aluminum alloy shell shall be adopted which is light but hard and fit for the use in the terrible work environment with a high heat dissipation rate and all tightness design.
- INVERSE PHASE SEQUENCE PROTECTING DEVICE:**
 It is the special electrical installation which control the circuit not to work in case of wiring error in the power supply.
- LIMIT SWITCH:** The limit switch device is installed where the weight is lifted on and off to make the motor to stop automatically so as to prohibit the chains from exceeding for safety.
- 24V/36V DEVICE:** It is used to prohibit the emergencies from occurring in case of the leakage in the switch.



Model : HHBD

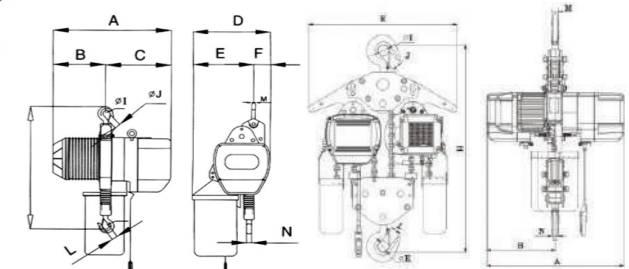
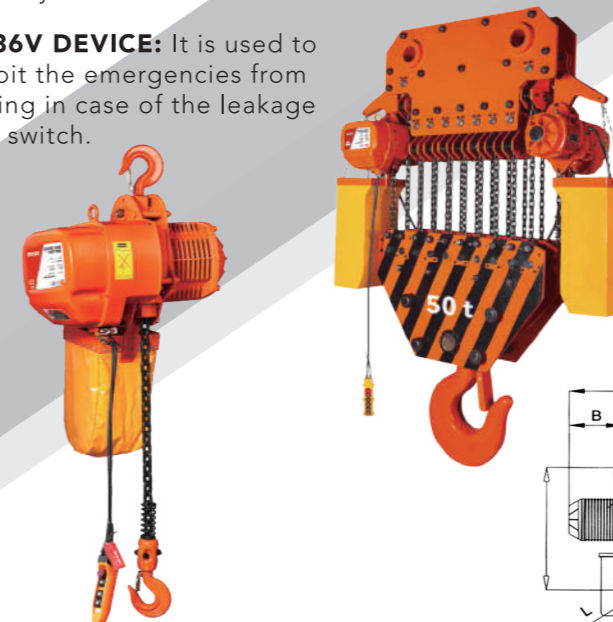

SIZE SPECIFICATION

Product code	Capacity (t)	Unit(mm)														Chain
		H	A	B	D	E	I	K	L	N	E	U	R	T		
HHBD0101	1	650	520	260	300	176	Φ31	Φ42	32	24	206	111	142	231	Φ7.1	
HHBD0151	1.5	770	615	295	430	265	Φ36	Φ49	40	30	237	127	142	231	Φ10.0	
HHBD0201	2	770	615	295	430	265	Φ36	Φ49	40	30	237	127	142	231	Φ10.0	
HHBD0202	2	815	520	260	300	236	Φ36	Φ49	40	30	237	127	142	231	Φ7.1	
HHBD0251	2.5	830	615	295	430	265	Φ43	Φ59	48	35	265	140	142	231	Φ11.2	
HHBD0301	3	830	615	295	430	265	Φ43	Φ59	48	35	265	140	142	231	Φ11.2	
HHBD0302	3	930	615	295	430	320	Φ43	Φ59	48	35	265	140	142	231	Φ10.0	
HHBD0303	3	940	520	260	350	205	Φ43	Φ59	48	35	265	140	142	231	Φ7.1	
HHBD0502	5	1015	615	295	430	325	Φ54	Φ60	48	43	297	156	142	231	Φ11.2	
HHBD1004	10	1207	620	310	310	380	Φ70	Φ90	80	60	890	191	142	231	Φ11.2	



ELECTRIC CHAIN HOIST

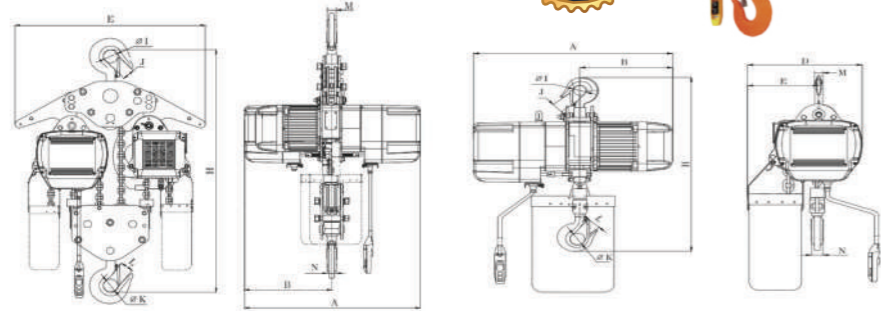
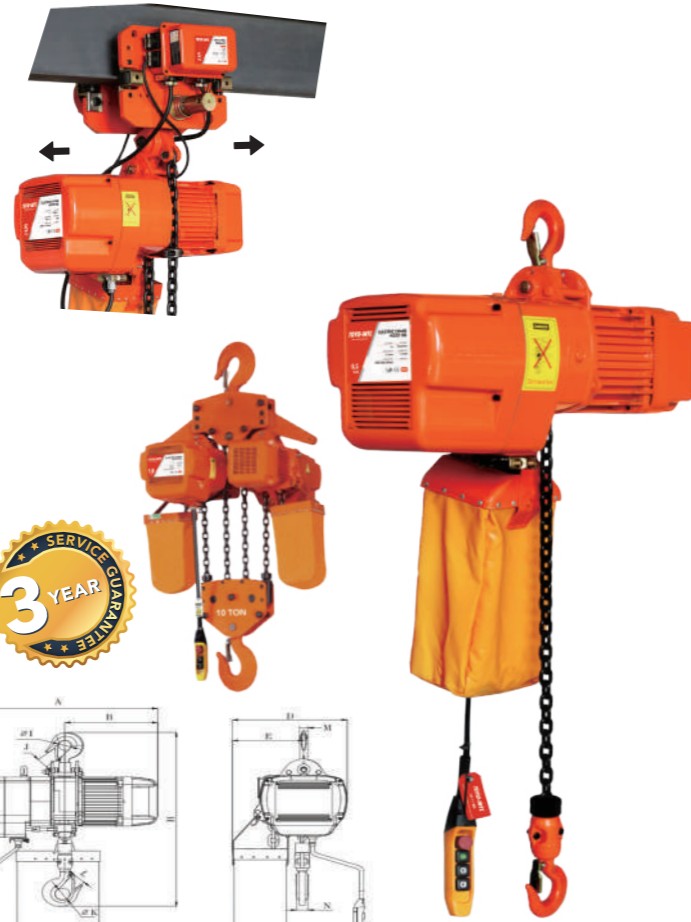

Model :KD

TECHNICAL SPECIFICATION

Model	Load Capacity (t)	Lifting Height (m)	Load Chain		Lifting Speed (m/min)	Travelling Speed (m/min)	Lifting Motor				Running Motor				I-Steel Track (mm)	Net Weight (kg)	Gross Weight (kg)			
			Diameter (mm)	Chain Fall Number			Power (Kw)	E.D. Rating (%)	Rotary Speed (m/min)	Phase	Voltage (V)	Frequency (Hz/s)	Power (Kw)	Rotary Speed (m/min)				Phase	Voltage (V)	Frequency (Hz/s)
ELECTRIC HOIST KD	0.5T	6	6.3	1	6.8	11	0.75	40	1440	3Phase	380V	50	0.4	1440	3Phase	380V	50	85-125	44	51
	0.5T	12	6.3	1	6.8	11	0.75	40	1440	3Phase	380V	50	0.4	1440	3Phase	380V	50	85-125	50	57
	1T	6	7.1	1	6.6	11	1.5	40	1440	3Phase	380V	50	0.4	1440	3Phase	380V	50	88-153	56	65
	1T	12	7.1	1	6.6	11	1.5	40	1440	3Phase	380V	50	0.75	1440	3Phase	380V	50	88-153	62	71
	2T	6	10	1	5.4	11	3	40	1440	3Phase	380V	50	0.75	1440	3Phase	380V	50	82-178	106	72
	2T	12	10	1	5.4	11	3	40	1440	3Phase	380V	50	0.75	1440	3Phase	380V	50	82-178	118	84
	3T	6	11.2	1	5.4	11	3	40	1440	3Phase	380V	50	0.75	1440	3Phase	380V	50	100-178	114	127
	3T	12	11.2	1	5.4	11	3	40	1440	3Phase	380V	50	0.75	1440	3Phase	380V	50	100-178	132	145
	5T	6	11.2	2	2.7	11	3	40	1440	3Phase	380V	50	0.75	1440	3Phase	380V	50	112-178	145	159
	5T	12	11.2	2	2.7	11	3	40	1440	3Phase	380V	50	0.75	1440	3Phase	380V	50	112-178	181	195
	10T	6	11.2	4	2.7	11	3.0*2	40	1440	3Phase	380V	50	0.75	1440	3Phase	380V	50	150-220	335	338
	10T	12	11.2	4	2.7	11	3.0*2	40	1440	3Phase	380V	50	0.75	1440	3Phase	380V	50	150-220	407	434

DIMENSION SPECIFICATION

Model	Load Capacity (t)	Dimensions(mm)										Net weight (kg)	Gross Weight (kg)	
		H	A	B	D	E	I	J	K	L	M			N
ELECTRIC HOIST KD	0.5T	455	566	266	285	165	26	27	34	25	17	17	19	22
	1T	520	627	302	300	176	26	32	41	32	24	24	36	44
	2T	640	733	343	430	265	31	38	49	40	28	28	47	52
	3T	685	733	343	430	265	36	48	59	48	34	34	57	63
	5T	870	733	343	430	325	43	48	60	48	42	42	76	83
	10T	1270	780	890	-	890	85	70	85	70	104	60	124	135

ELECTRIC CHAIN HOIST

- Compact and high efficient motor:**
 DC brake system without asbestos, consumption of electricity reduced efficiently.
- Hoist body**
 Pressing steel structure, high strength body, light and compact.
- Most tensile safety hooks:**
 Both the top and bottom hook made of high tensile alloy steel, with special Treatment, it guarantees the hook will not break, and will deform gradually under a sudden extraload.
- Compact and beauty chain container:**
 High strength plastic container has outstanding durability.
- Limit switch devices:**
 Fitted at top and bottom ends, switch off power automatically to prevent Load chain from running out.
- Phase error relay:**
 A specially designed current-post, prevents motor from running at incorrect Wire connection.



Model :HHBT

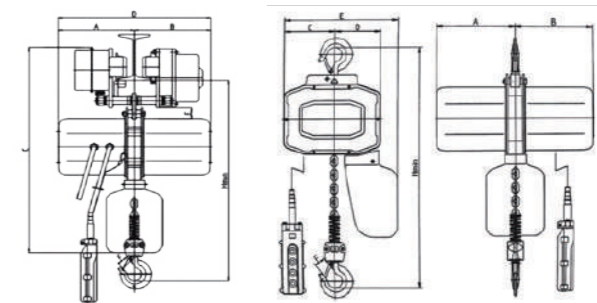

SPECIFICATION

Model	HHBT-0.5a	HHBT-1.0a	HHBT-2.0a	HHBT-3.0a	HHBT-5.0a	HHBT-10.0a
Capacity(t)	0.5	1.0	2.0	3	5.0	10.0
Standard lift (m)	3	3	3	3	3	3
Running test load(t)	0.625	1.25	2.5	3.75	6.25	12.5
Motor power(kw)	0.8	1.6	1.6	1.6	3.0	2*3.0
No.of chain	1	1	2	3	3	6
Load chain diameter(mm)	7.1	7.1	7.1	7.1	7.1	7.1
Lifting speed(m/min)	7	7	3.5	2.3	2.6	2.6
Power Supply	380V/50HZ/3P	380V/50HZ/3P	380V/50HZ/3P	380V/50HZ/3P	380V/50HZ/3P	380V/50HZ/3P
Control Voltage (V)	24V	24V	24V	24V	24V	24V
Dimensions(mm)	A	245	245	245	245	265
	B	245	245	245	245	265
	C	158	158	124	124	127
	D	142	142	176	176	205
	E	350	350	350	350	393
F	600	600	610	620	738	
Net weight(kg)	50	55	60	65	100	950
Extra Weight Per Meter of Extra lift(KG)	1.1	1.1	2.2	3.3	5.2	10.4



ELECTRIC HOIST

- Aluminum Alloy Casting, solid and light with simple structure.
- Copper wire winding motor, small resistance, high temperature resistance, not easy to burn the motor.
- Adopts anti-rotation aviation special steel wire rope with high safety factor and long service life.
- It is made of High Quality alloy material and is forged into a 360 - degrees rotating. Anti-skid hook, The safety performance is higher.



LOW - NOISE

Ultra Quiet deceleration system, high transmission efficiency.



SMART LIMITER

The limit device automatically stops the operation when the limit baffle hits the limiter.

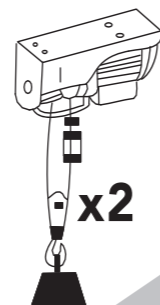
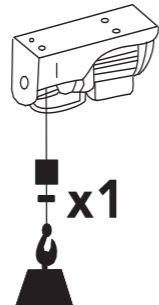

Motor stator



Rotors

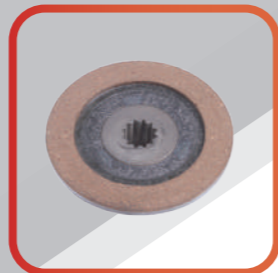

Brake pads



Model :PA



Model :PAW



SPECIFICATION

Model	PA200	PA250	PA400	PA500	PA600	PA800	PA1000	PA1200
Rated volt(V)			220/230V 50HZ		S320%10min			
Input Power(w)	510	530	980	1020	1200	1300	1600	1900
Capacity load(kg)	100/200	125/250	200/400	250/500	300/600	400/800	500/1000	600/1200
Lifting height(m)	12/6	12/6	12/6	12/6	12/6	12/6	12/6	12/6
Lifting speed (m/min)	10/5	10/5	10/5	10/5	10/5	10/5	10/5	10/5
Packing dimensions(cm)	38×32×25	38×32×25	45×34×27	45×34×27	45×34×27	45×34×27	54×25×32	54×25×32
G.W/N.W(kg)	24/22	25/24	25/33	36/34	41/38	38/36	40/38	32.5/31.5
Quan/CTM(pcs)	2	2	2	2	2	2	1	1

SPECIFICATION OF TROLLRY

Model	Rated Capacity (T)	Assembling Height (m)	Moving Speed (m/min)	Rated Volt (v)	Power (V)	Speed (r/min)	Min Radius of Crooked Track which Can pass (m)	Model of steel Beam (a)	Width of Track (mm)	N.W. (kg)
TD-0.5	0.5	6	13	AC 100/ 110 /120/220	160	1400	1	10-18	68-94	14
TD-1	1.0	6	13	AC 100/ 110 /120/220	540	1400	1.5	14-20	80-102	18
TD-1.2	1.2	6	13	AC 100/ 110 /120/220	540	1400	1.5	14-20	80-102	19



WIRE ROPE ELECTRIC HOIST

- **Reducer:** Third-class dead axel helical gear transmission structure is adopted; gear and gear axel are made of heat treated alloy steel; case and case cover with precise assembly and good seal are made of quality cast iron. The reducer is independent, so it's easy to load and unload it.
- **Control Box:** It has device with up and down stroke protection of break off limiter and can cutoff main circuit in an emergency, which ensures safe operation of electric block electric elements are of long service life and operational safety.



SPECIFICATION

CD1/MD1(CD1Y/MD1Y)																																			
Capacity(t)	0.5		1		2		3		5		10																								
Jnorm Working Level	M3		M3		M3		M3		M3		M3																								
Hoisting Height(m)	6	9	12	18	24	30	6	9	12	18	24	30	6	9	12	18	24	30	6	9	12	18	24	30	6	9	12	18	24						
Hoisting Speed (m/min)	8(8/0.8)		8(8/0.8)		8(8/0.8)		8(8/0.8)		8(8/0.8)		7(7/0.7)																								
Operating speed (suspended type)(m/min)	20(20/6.7) 30(30/10)		20(20/6.7) 30(30/10)		20(20/6.7) 30(30/10)		20(20/6.7) 30(30/10)		20(20/6.7) 30(30/10)		20(20/6.7)																								
Multiplying power of Chain Wheel	2/1		2/1		2/1		2/1		2/1		4/2																								
Type and power of Hoisting Electric Motor(kw)	ZDY11-4(0.8)		ZDY22-4(1.5)		ZD31-4(3)		ZDY32-4(4.5)		ZD41-4(7.5)		ZD51-4(13)																								
(Motor type and power (suspended type) (kw)	ZDSI-0.2/0.8(0.2/0.8)		ZDS-0.2/1.5(0.2/1.5)		ZDSI-0.4/3(0.4/3)		ZDSI-0.4/4.5(0.4/4.5)		ZDSI-0.8/7.5(0.8/7.5)																										
Level of Protection	IP44	IP54	IP44	IP54	IP44	IP54	IP44	IP54	IP44	IP54	IP44	IP54																							
Type of I-Steel Track	116a~128b		116a~128b		120a~145c		120a~145b		125a~163c		140a~163c																								
Minimum Turning Radius(m)	1	1	1.1	1.2	1.8	2.5	3.2	1.2	1.2	1.5	2.0	2.8	3.5	1.2	1.2	1.5	2.0	2.8	3.5	1.5	1.5	1.5	2.5	3.0	4.0	1.5	1.5	1.5	2.5	3.0					
Net weight(kg)	90	115	119	134	149	164	110	130	140	165	182	197	193	198	228	260	300	330	242	246	285	320	370	381	355	355	420	480	540	600	760	840	920	1000	1060



Model :CD1/MD1



- **Steel wire rope:** It uses GB1102-74(6x37+1) hoist steel wire rope which is durable in use.
- **Conical Motor:** The hoist motor uses conical rotors of relatively stronger starting torque to brake asynchronous motor and F grade insulation and it's grade of protection is IP 44/IP 54.
- **Button Switch:** It's hand-operated,easy to handle, and has two modes of cord operation and cordless remote control.

ELECTRIC WIRE ROPE HOIST

- **MOTOR:** It uses cylindrical rotor motor, with high performance, high torque, easy to heat, high pressure resistance, large output power, it can be turning on frequently. Working class is level 5, protection class is IP54.
- **GEAR BOX:** The gear uses alloy steel and the shaft is high carbon steel with teh heat treatment, high quality and long service life. The gear box cover uses high strength nodular cast iron, machining center processing to ensure the machining accuracy and reduce vibration. The cover assembly uses the special seal washer which could be reliable for sealing.
- **BRAKE:** The device uses electromagnetic brake system, when the brake disc wear, it can automatically adjust the brake in order to ensure the safety. Once the main braking device caused the decilne of goods fell too fast, the auxiliary brake system will turn on, which is in order to prevent the goods fall, forming double brake mechanism.

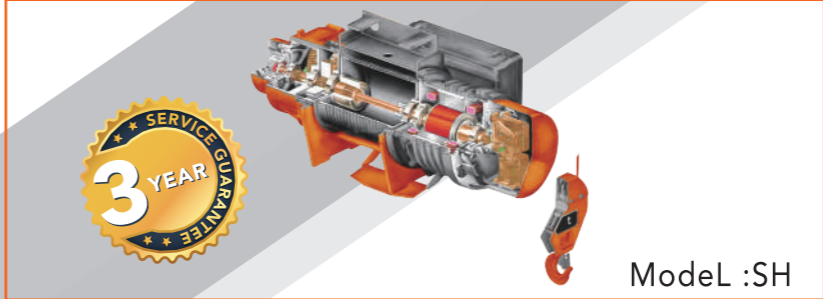

Model :SH

SPECIFICATION

Model	SH10	SH20	SH30	SH50	SH100				
Capacity(Ton)	1	2	3	5	10				
Lifting Height(m)	6	12	6	12	6	12	9	12	12
Lifting Motor(Kw)	3	3	5.5	7.5	11				
Lift Speed(M/min)	11	6.2	7.5	6.7	5				
Trolley Speed(M-min)	21	21	21	21	14				
Ropes	2Ropes	2Ropes	2Ropes	4Ropes	4Ropes				
Wire Rope	Rope Dia.(mm)	φ8	φ12	φ14	φ12	φ16			
	Wire Dia.(mm)	0.34	0.5	0.6	0.6	0.7			
	Structure Form	6×19-B	6×37-B	6×37-B	6×37-B	6×37+1-B			
I-BEAM Type	20a-45a	20a-45a	30a-63a	45a-63a	45a-63a				
Min.Curve Radius(m)	Type	1M6	2M7	3M6	5M5	10M			
	Power(kw)	3kw	3kw	6kw	7.5kw	11kw			
Hoisting Motor	Rotation								
	Speed(r/min)	1380	1380	1380	1380	1380			
	Voltage(F)	Frequency	380V/3F/50Hz	380V/3F/50Hz	380V/3F/50Hz	380V/3F/50Hz			
Trolley Motor	Current(Amp.)	6.44	6.44	12.8	15.6	22			
	Type	1T5	2T5	3T5	5T5	5T5			
	Power(kw)	0.4kw	0.4kw5	0.4kw	0.75kw	0.75×2kw			
Rotation	Rotation	1380	1380	1380	1380	1380			
	Speed(r/min)	1380	1380	1380	1380	1380			
	Voltage(F)	Frequency	380V/3F/50Hz	380V/3F/50Hz	380V/3F/50Hz	380V/3F/50Hz			
Current(Amp.)	1.5	1.5	1.5	2.2	2.2				
	Work Class	M4/30% ED	M4/30% ED	M4/30% ED	M4/30% ED	M4/30% ED			
Packaging Size(cm)	99*60*52	118*90*52	106*71*64	126*71*64	118*73*66	140*73*66	164*83*75	185*83*75	223*94*80
Gross Weight(kgs)	208	236	340	376	454	495	739	785	2840
Net Weight (kgs)	196	213	305	336	417	450	670	713	2640



ELECTRIC WIRE ROPE HOIST

Advanced technology and components can make sure the hoist in a optimal state even been used on limited size and height, on the premise of guarantee high performance, make the size as small as possible, TWH electric wire rope hoists occupy large working seppe compared with other hoists which used in the same workshop and same working area, increase workshop use ratio and decrease blind area.



Model L:SWH



Model L:DWH

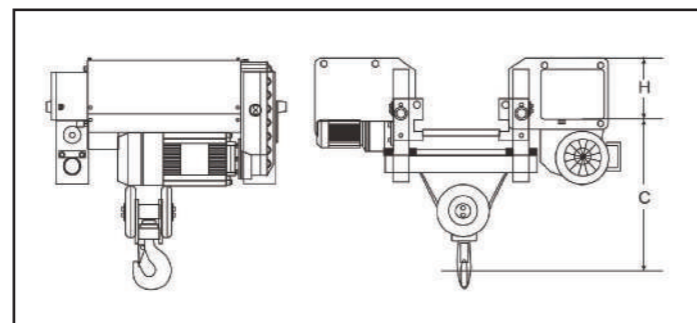

TECHNICAL PARAMETERS- SWH

Capacity(kg)	Lift Height(m)	Lifting Speed(m/min)	Traveling Speed(m/min)	Traveling Power(kw)	Hoist Work Group(fem/iso)	H Size(mm)	C Size(mm)
1000	6/9/12/15/18	1.6/10	5/20	0.2	4m/M7	235	485
1250	6/9/12/15/18	1.6/10	5/20	0.2	3m/M6	235	485
1600	6/9/12/15/18	0.8/5	5/20	0.2	3m/M6	235	555
1600	6/9/12/15/18	1.3/8	5/20	0.2	4m/M7	235	555
2000	6/9/12/15/18	0.8/5	5/20	0.31	2m/M5	235	585
2000	6/9/12/15/18	1.3/8	5/20	0.31	3m/M6	235	595
2500	6/9/12/15/18	0.8/5	5/20	0.31	3m/M6	235	595
2500	6/9/12/15/18	1.3/8	5/20	0.31	2m/M5	235	595
3200	6/9/12/15/18	1.0/6.3	5/20	0.31	2m/M5	235	595
3200	6/9/12/15/18	0.8/5	5/20	0.44	2m/M5	235	595
5000	6/9/12/15/18	0.8/5	5/20	0.44	2m/M5	251	595
5000	6/9/12/15/18	1.3/8	5/20	0.44	1Am/M4	251	595
5000	6/9/12/15/18	1.6/10	5/20	0.44	2m/M5	317	765
5000	6/9/12/15/18	1.3/8	5/20	0.44	3m/M6	317	765
6300	6/9/12/15/18	0.8/5	5/20	0.64	2m/M5	251	595
6300	6/9/12/15/18	1.0/6.3	5/20	0.64	3m/M6	317	765
6300	6/9/12/15/18	0.8/5	5/20	0.64	4m/M7	317	765
8000	6/9/12/15/18	1.3/8.0	5/20	0.64	3m/M6	317	765
8000	6/9/12/15/18	1.0/6.3	5/20	0.96	1Am/M4	317	765
10000	6/9/12/15/18	0.8/5	5/20	0.96	2m/M5	317	765
10000	6/9/12/15/18	1.0/6.3	5/20	0.96	1Am/M4	317	765
12500	6/9/12/15/18	0.66/4	5/20	0.96	2m/M5	317	765
12500	6/9/12/15/18	0.8/5	5/20	0.96	1Am/M4	317	765
5000	18/22/26/30	1.6/10	5/20	0.44	2m/M5	317	765
8000	18/22/26/30	1.3/8	5/20	0.96	2m/M5	364	900
10000	18/22/26/30	1.3/8	5/20	0.96	1Am/M4	364	900
16000	6/9/12/15/18	0.66/4	5/20	0.96×2	2m/M5	364	850

PRODUCT FEATURES

Modular design ,more options meet customers' various needs.

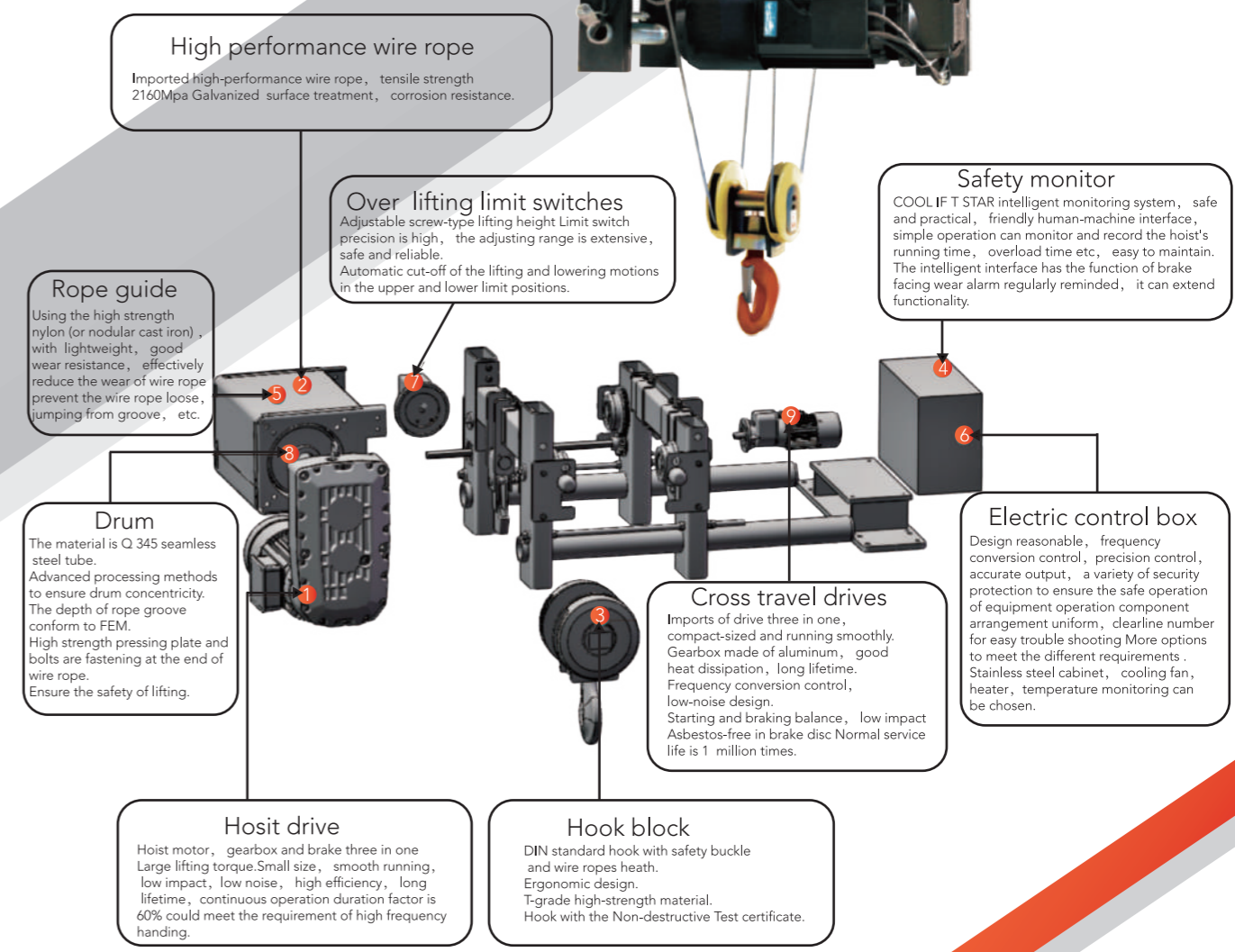



LIGHT WEIGHT HANGING TYPE HOIST

- Permanent magnet frequency conversion technology, stable lifting and falling without shaking. Intelligent integrated control appliances can save energy by more than 45%. Electrical control 4v low voltage is safe and reliable, no worry about electric shock.
- Overload and overheat protection can ensure safe and durable, and high and low speed can be switched at will, which make the machine suitable for different scenarios.
- Optional-accurate weight display and real-time monitoring, record keeping for query, wireless control + wireless communication.
- Overwind prevent device: when wire to the upper limit, power cut off automatically, and machine stop automatically to prevent collisions.

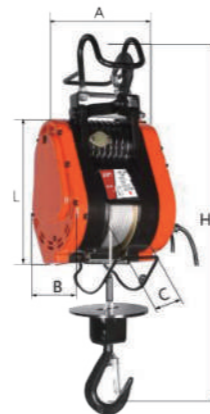

Model :TC

Technical Parameters

Model	Lifting Capacity (kg)	Permanent magnet inverter motor (Kw)	Lifting speed (m/min)	Brake	Lifting height (m)	wire rope (mmxm)	Power supply (m)	Control line (m)	Hook type	N.W (kg)	G.W (kg)	Package size (cm)
TC100DS	100	1.5	10 30	electric+ manual	29	5x30	4.5	6	N1	16	19	50x30x28
TC160DS	160		9 24									
TC190DS	190		8 21									
TC250DS	250		7 18									
TC300DS	300		6 15									
TC350DS	350	5 14										
TC190DSK	190	2.5	12 34	electric+ manual	49	5x50	4.5	6	N1	24	28	55x33x31
TC250DSK	250		11 30									
TC300DSK	300		10 27									
TC350DSK	350		9 24									
TC280DS	280		10 28									
TC360DS	360	9 23										
TC500DS	500	2.5	7 17	electric+ manual	29	6x30	4.5	6	N1	24	28	55x33x31
TC750DS	750		6 15									

MINI ELECTRIC CHAIN HOIST

- Permanent magnet frequency conversion technology, stable lifting and falling without shaking. Intelligent integrated control appliances can save energy by more than 45%. Electrical control 4v low voltage is safe and reliable, no worry about electric shock.
- Small button switch, easy operation.
- Optional-accurate weight display and real-time monitoring, record keeping for query, wireless control + wireless communication.
- Overwind prevent device: when wire to the upper limit, power cut off automatically, and machine stop automatically to prevent collisions.



Model :TA



Technical Parameters

Model	Lifting Capacity (kg)	Permanent magnet inverter motor (Kw)	Lifting speed (m/min)	Brake	Lifting height (m)	chain (mm)	Power supply (m)	Control line (m)	Hook type	N.W (kg)	G.W (kg)	Package size (cm)
TA-300DS	300	1.5	5 9	electric+ manual	3	5x15	4.5	2.5	H105	16	18	50x25x40
TA-500DS	500		4 6.8									
TA-500DSK	500		6 10									
TA-1000DS/2	1000	2.5	3 5	electric+ manual	7x21	4.5	2.5	H102	20	22		
TA-1000DS	1000		4 6.8									
TA-2000DS	2000		2 3.4									



ELECTRIC CHAIN HOIST

- TA chain hoist combines strong body with flexible design together, it can be replaced quickly without dismantling the whole hoist, makes it easy to detect the use status of electrical appliances and brake high efficiency, saving maintenance time and reduce cost.
- 220V-480V range optional input voltage and 36V standard safety control voltage (optional 24/48V) bringing more optional ranges to customers from all over the world.

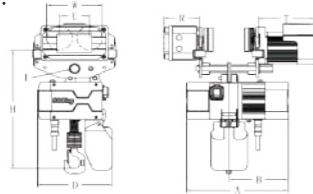

Model : TD

Technical Parameters

Model	H	A	B	R	T	I	W	U	D
TD0.5-01	471	375	218	145	210	Φ31	206	112	275
TD01-01	471	396	239	145	210	Φ31	206	112	275
TD01-02	538	375	218	145	210	Φ31	206	112	275
TD02-02	573	396	239	145	210	Φ31	206	112	275

Model	Capacity (Ton)	Lifting Height (m)	Lifting speed (m/min)	running speed (m/min)	Hoist Power (Kw)	Hoist Power (Kw)	Rotation speed (r/min)	Phases	Voltage (V)	Control Voltage (V)	Weight (Kg)	Rating
TD0.5-01	500	4	8	21	0.8	0.4	1440	3/2	110-480	24-48	58/61	M5
TD01-01	1000	4	8	21	1.1	0.4	1440	3/2	110-480	24-48	68/70	M5
TD01-02	1000	4	8	21	1.1	0.4	1440	3/2	110-480	24-48	68/70	M5
TD02-02	2000	4	8	21	1.1	0.8	1440	3/2	110-480	24-48	65/68	M5

ELECTRIC WINCH



Model : TB

Technical Parameters

Model	Lifting Capacity (kg)	Permanent magnet inverter motor (Kw)	Lifting speed (m/min)	Brake	Lifting height (m)	wire rope (mmxmm)	Power supply (m)	Control line (m)	Hook type	N.W (kg)	G.W (kg)	Package size (cm)
TB200DS	200	1.5	8 18	electric+ manual	28	5*30	4.5	6	N1	18	22	54*25*30
TB200DS L	200		8 18		68	5*70				22	26	60*25*30
TB200DS LL	200		8 18		118	5*120				25	29	66*25*30
TB300DS	300	1.5	6 15	electric+ manual	28	6*30	4.5	6	N1	18	22	54*25*30
TB300DS L	300		6 15		58	6*60				22	26	60*25*30
TB300DS LL	300		6 15		88	6*90				25	29	66*25*30
TB500DS	500	1.5	7 17	electric+ manual	28	7*30	4.5	6	N1	18	22	54*25*30
TB500DS L	500		7 17		43	7*45				22	26	60*25*30
TB500DS LL	500		7 17		58	7*60				25	29	66*25*30
TB200DSK	200	2.5	13 35	electric+ manual	28	5*30	4.5	6	N1	18	22	54*25*30
TB200DSK L	200		13 35		68	5*70				22	26	60*25*30
TB200DSK LL	200		13 35		118	5*120				25	29	66*25*30
TB300DSK	300	2.5	10 26	electric+ manual	28	6*30	4.5	6	N1	18	22	54*25*30
TB300DSK L	300		10 26		58	6*60				22	26	60*25*30
TB300DSK LL	300		10 26		88	6*90				25	29	66*25*30



ELECTRIC CHAIN HOIST

- This product is designed for lifting and moving heavy duty applications. It operates on the standard 120 Volts power supply, making it easy to power in a variety of situations, perfect for mechanics and small machine shops.
- Completely enclosed design. Entire mechanism including; the motor, dual brake system, gears, rotating parts and electrical system can be operated under severe conditions.
- Chain bucket has a noiseless design with flexible mounting.
- High quality Grade 80 zinc plated load chain supplied as standard.
- This electric chain hoist's electro magnetic brake increases safety by holding a load even if power is interrupted.



Model :MNEH



Model :MNEH



Built-in chain bag



Robust motor & Durable shell



Heavy-duty bottom hooks



G80 lever chain

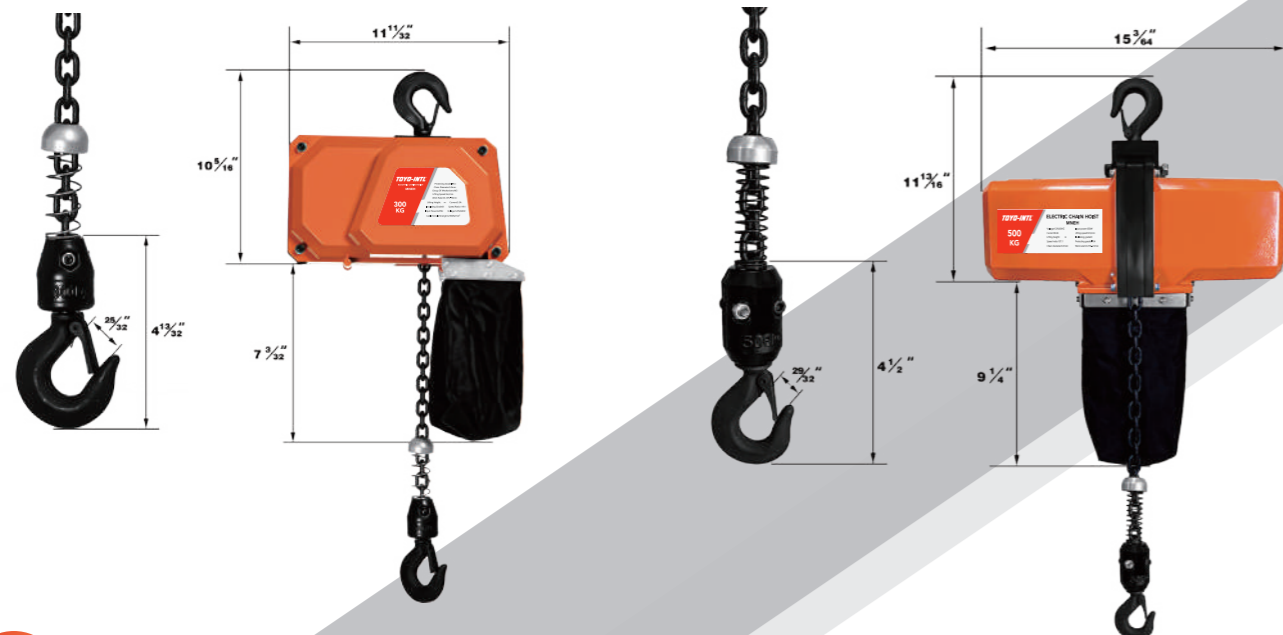

Technical Parameters

Model	Voltage	Input Power	Lifting Weight	Lifting Speed	Lifting Height	Chain Diameter	Qty	Packing Dimension	N.W.	Method of Use
MNEH150	120/230V	270/240W	150KG	3m/min	3m	4mm	1pcs	32×30×25cm	7.9KG	Single Hook
MNEH300	120/230V	500/430W	300KG	3m/min	3m	5mm	1pcs	37×37×28cm	14.3KG	Single Hook
MNEH500	120/230V	720/680W	450/500KG	4/3m/min	3m	6.3mm	1pcs	48×37×32cm	18.5KG	Single Hook



TEXTILE SLING EB WEBBING SLING

- Material Double Ply Polyester web sling width reinforced lifting eyes.
- Web Sling colour coded according to EN 1492-1(7:1).
- Each sling is packed with CE declaration of conformity.

POLYESTER MATERIAL

Elongation at breaking force	ca. 12%
Elongation at WLL	ca. 3%
Elongation - resistance in wet condition	100%
Compared wear - resistance	80
Specific weight	1.38

PRODUCT IDENTITY
TOYO-INTL Webbing Sling original product with label tag logo on polyester material.



EB Webbing Sling's lifting method and maximum Safety Working Load parameter.

Code	Color	Max. SWL = Mode Coefficient P* Working Load Limit						Max. SWL of Lifting Method				Approx. Width (mm)	Min. Length (m)	Max. Length (m)		
		Single Max. Working Load Limit						2-Leg Max. Working Load Limit								
		Upright	Choked	β				Upright 45°	Choked 45°	Upright 45°-60°	Choked 45°-60°					
				0° -7°	7° -45°	45° -60°	45°									
EB-01		1000	800	2000	1400	1000	700	1400	1120	1000	800	5:1	6:1	7:1	1	100
EB-02		2000	1600	4000	2800	2000	1400	2800	2240	2000	1600	25	25	30	1	100
EB-03		3000	2400	6000	4200	3000	2100	4200	3360	3000	2400	75	75	90	1	100
EB-04		4000	3200	8000	5600	4000	2800	5600	4480	4000	3200	100	100	120	1	100
EB-05		5000	4000	10000	7000	5000	3500	7000	5600	5000	4000	125	125	150	1	100
EB-06		6000	4800	12000	8400	6000	4200	8400	6720	6000	4800	150	150	180	1	100
EB-08		8000	6400	16000	11200	8000	5600	11200	8960	8000	6400	200	200	240	1	100
EB-10		10000	8000	20000	14000	10000	7000	14000	11200	10000	8000	250	250	300	1	100
EB-12		12000	9600	24000	16800	12000	8400	16800	13440	12000	9600	300	300	300	1	100
EB-15		15000	12000	30000	21000	15000	10500	21000	16800	15000	12000	200	200	240	1	100
EB-20		20000	16000	40000	28000	20000	14000	28000	22400	20000	16000	250	250	300	1	100
EB-25		25000	20000	50000	35000	25000	17500	35000	28000	25000	20000	300	300	300	1	100
EB-30		30000	24000	60000	42000	30000	21000	42000	33600	30000	24000	300	300	300	1	100
EB-40		40000	32000	80000	56000	40000	28000	56000	44800	40000	32000				1	100
EB-50		50000	40000	100000	70000	50000	35000	70000	56000	50000	40000				1	100

CARGO LASHING SERIES

- Our range of tie downs, are manufactured as well with Ultra high tenacity Yarns, either in Polyester or in Polypropylene.
- Our Polypropylene tie downs series, are guaranteed to a usage under UV light for 3 years.
- Our new series of tie downs include, edge cutting resistant tapes, and others as antisliding, properties up to a 100% over other's existent in the market, or in our catalog, also we include the New series of automatic Retractable ratchet 50 and 25.
- All our manufacturing is automated as possible, to avoid as minimum labor error, i.e. our stitching.

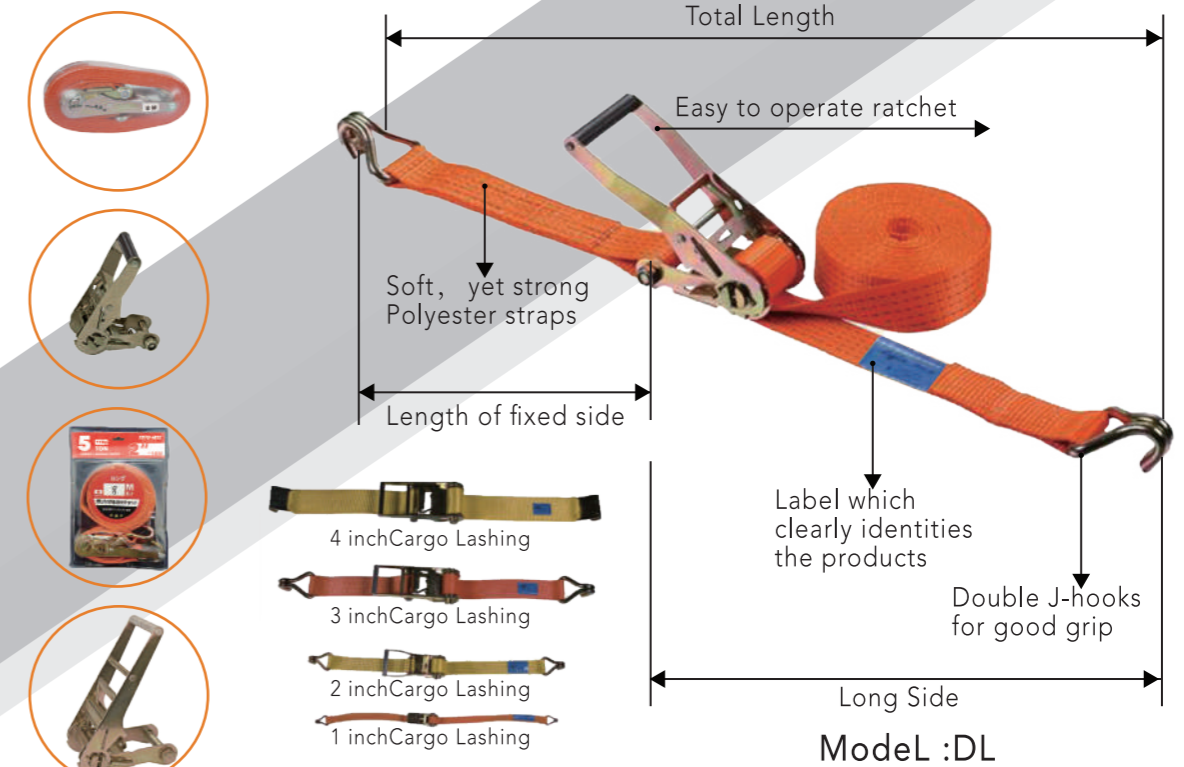

Model	Explanation	Working Load(kg)	Working length(m)	Webbing width(mm)/(inch)
DL010	1 T,4~8m	1000	4~8	25 (1")
DL015	1.5 T,4~8m	1500	4~8	25 (1")
DL020	2 T,4~8m	2000	4~8	38 (1.5") /50 (2")
DL030	3 T,4~12m	3000	4~12	38 (1.5") /50 (2")
DL040	3 T,4~12m	3000	4~12	50 (2")
DL050	5 T,4~12m	5000	4~12	50 (2")
DL080	8 T,5~12m	8000	4~12	75 (3")
DL100	10 T,5~12m	10000	4~12	100 (4")



ROUND SLING

- Round sling has the maximum load upto 3000T, effective length upto 100m, safety factor adopted is normally 7: 1, 6: 1.
- Round sling is made of high tension industrial yam(100%PES) ,the strands inside areas a form of endless cycle.The outside sleeve is also made of 100%PES,not for the loading,but to protect the strands inside.



Model :EA

EA Round Sling's lifting method and maximum Safety Working Load parameter.

Type	WLL(T)	Width(mm)	Color	Working Load Limit						Multi-set			
				Vertical	Choker	Basket	7' <b<45' Basket	7' <b<60' Basket	B<45'	B<45'	Approx. Width (mm)	Min. Length (m)	Max. Length (m)
				100%	80%	200%	140%	100%	140%	112%			
EA005	0.5	1" /25		500	400	1000	700	500	700	560			
EA010	1	2" /50		1000	800	2000	1400	1000	1400	1120			
EA015	1.5	3" /75		1500	1200	3000	2100	1500	2100	1680			
EA020	2	4" /100		2000	1600	4000	2800	2000	2800	2240			
EA025	2.5	5" /125		2500	2000	5000	3500	2500	3500	2800			
EA030	3	6" /150		3000	2400	6000	4200	3000	4200	3360			
EA040	4	8" /200		4000	3200	8000	5600	4000	5600	4480			
EA050	5	10" /250		5000	4000	10000	7000	5000	7000	5600			
EA060	6	12" /300		6000	4800	12000	8400	6000	8400	6720			

EA-A ROUND SLING

The unique advantages of round slings:

- Especially suitable for loading round object.
- The surface of round sling is smooth, does not cause damages to tender objects loaded.
- Various loading methods, including dragging or pulling loaded object.
- Various loading methods and load is bear evenly, enable the sling's usage life last longer.
- High strength/weight ratio.



Model :EA-A

Round Sling in Choker Hitch

Round Sling in Straight Lift

EA-A Round Sling's lifting method and maximum Safety Working Load parameter.

Code	Color	Max. SWL=Mode Coefficient *Working Load Limit						Max. SWL of Lifting Method				Approx. Width (mm)	Min. Length (m)	Max. Length (m)
		Single Max. Working Load Limit						2-Leg Max. Working Load Limit						
		Upright	Choked	β				Upright	Choked	Upright	Choked			
				0°-7°	7°-45°	45°-60°	45°							
		1.0	0.8	2.0	1.4	1.0	0.7	1.4	1.12	1.0	0.8			
EA-A-01		1000	800	2000	1400	1000	700	1400	1120	1000	800	50	1	100
EA-A-02		2000	1600	4000	2800	2000	1400	2800	2240	2000	1600	60	1	100
EA-A-03		3000	2400	6000	4200	3000	2100	4200	3360	3000	2400	70	1	100
EA-A-04		4000	3200	8000	5600	4000	2800	5600	4480	4000	3200	75	1	100
EA-A-05		5000	4000	10000	7000	5000	3500	7000	5600	5000	4000	80	1	100
EA-A-06		6000	4800	12000	8400	6000	4200	8400	6720	6000	4800	90	1	100
EA-A-08		8000	6400	16000	11200	8000	5600	11200	8960	8000	6400	100	1	100
EA-A-10		10000	8000	20000	14000	10000	7000	14000	11200	10000	8000	110	1	100
EA-A-12		12000	9600	24000	16800	12000	8400	16800	13440	12000	9600	125	1	100
EA-A-15		15000	12000	30000	21000	15000	10500	21000	16800	15000	12000	150	1	100
EA-A-20		20000	16000	40000	28000	20000	14000	28000	22400	20000	16000	180	1	100
EA-A-25		25000	20000	50000	35000	25000	17500	35000	28000	25000	20000	200	1	100
EA-A-30		30000	24000	60000	42000	30000	21000	42000	33600	30000	24000	220	1	100
EA-A-40		40000	32000	80000	56000	40000	28000	56000	44800	40000	32000	250	1	100
EA-A-50		50000	40000	100000	70000	50000	35000	70000	56000	50000	40000	270	1	100
EA-A-60		60000	48000	120000	84000	60000	42000	84000	67200	60000	48000	280	1	100
EA-A-80		80000	64000	160000	112000	80000	56000	112000	89600	80000	64000	300	1	100
EA-A-100		100000	80000	200000	140000	100000	70000	140000	112000	100000	80000	320	1	100



GEARED TROLLEY

- High grade sealed ball bearings.
- With anti - drop plates.
- Galvanized hand chain.
- All structural parts made of high quality steel.
- Adjustable to any beam width, simply by adjusting the number of collars.
- For geared trolley, the standard operating length is 3 meter, other length is available upon request.

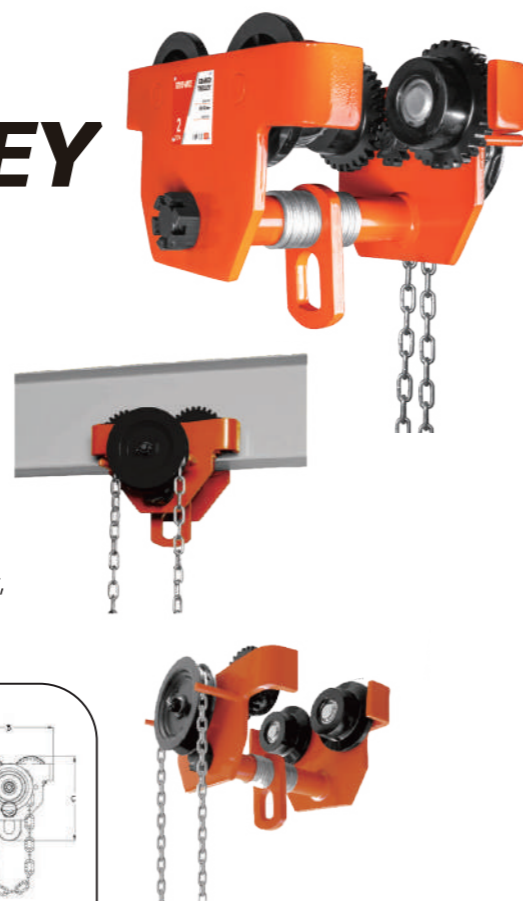

Model :GCL-B



ADJUSTABLE WIDTH
The wheels are made to fit any shape of a beam.

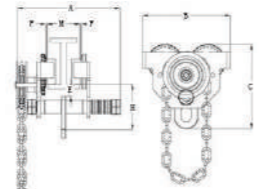

GEAR GUIDE MECHANISM
Gear guide mechanism in flanged load sheave and guide roller facilitate smooth movement.

TECHNICAL SPECIFICATION

Capacity (t)	I-BEAM(mm) M	Dimensions(mm)						Net weight (kg)	Carton Size (mm)
		A	B	C	E	H	F		
1T*5M	75-120mm	258	250	214	11	118	1, 5-3	13.2	305*160*175
2T*5M	80-140mm	284	270	227	14	125	1, 5-3	17.8	330*170*205
3T*5M	80-142mm	312	315	304	8	165	1, 5-3	26.1	390*200*235
5T*5M	95-168mm	365	358	334	21	183	1, 5-3	39.4	440*235*270
10T*5M	100-255mm	458	430	434	36	250	1, 5-3	75	590*310*400
20T*5M	140-210mm	595	518	524	45	324	1, 5-3	190	610*415*525

PLAIN TROLLEY

- All structural parts made of high quality steel.
- Adjustable to any beam width, simply by adjusting the number of collars.
- High grade sealed ball bearings.
- With anti - drop plates.
- Galvanized hand chain.



MOVEMENT MECHANISM
Trolley moves smoothly on cast iron flanged wheels equipped with sealed, lubed for life ball bearings.



ADJUSTABLE WIDTH
The wheels are made to fit any shape of a beam.



Model :GCT-B

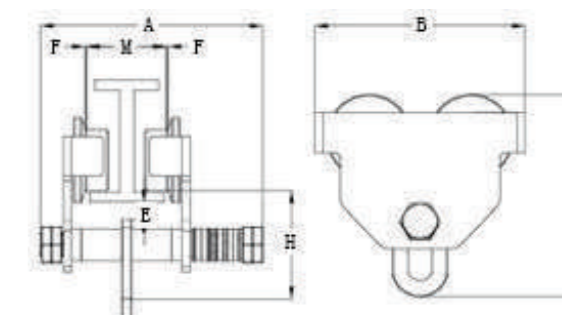

TECHNICAL SPECIFICATION

Capacity (t)	I-BEAM(mm) M	Dimensions(mm)						Net weight (kg)	Carton Size (mm)
		A	B	C	E	H	F		
0.5T	75-120mm	198	204	188	23	113	1.5-3	6	295*75*185
1T	80-140mm	220	250	214	11	118	1.5-3	8	310*100*200
2T	80-142mm	243	270	227	14	125	1.5-3	11	340*130*210
3T	95-168mm	268	315	304	8	165	1.5-3	22	395*130*250
5T	100-255mm	305	358	334	21	183	1.5-3	30	440*150*300
10T	140-210mm	405	430	434	36	250	1.5-3	79	500*280*350



SERIES GEARED TROLLEY

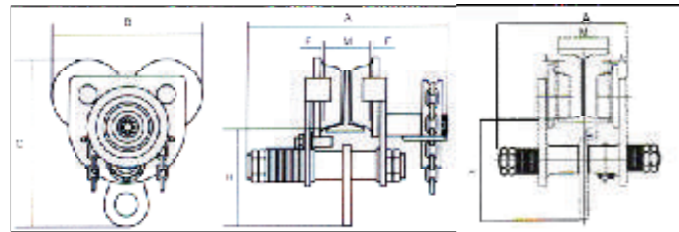

Model :GCL-A

Model	Capacity(t)	Compatible Rail Size(mm)		Geared Trolley GCL-A Specification									Min.rotation Radius(mm)	Net Weight (kg)
		Width(W) Min.	Max.	Height(H) Min.	Max.	A	B	C	D	E	F	K		
GCL-A10	1	75	125	125	250	206	231	120	Φ45	Φ80	27	117	1300	14.0
GCL-A20	2	100	150	150	400	241	271	155	Φ60	Φ100	33	119	1500	23.5
GCL-A30	3	100	150	180	400	261	311	185	Φ70	Φ113	47	134	2000	33.5
GCL-A50	5	125	175	250	450	294	351	220	Φ80	Φ125	53	134	2600	53.5
GCL-A100	10	150	175	250	450	294	721	165	-	Φ125	53	134	-	101.0

- Heavy duty construction with premium quality.
- Close headroom by design.
- Choose from either push or hand geared travel.
- Available to suit larger beam widths up to 310mm.

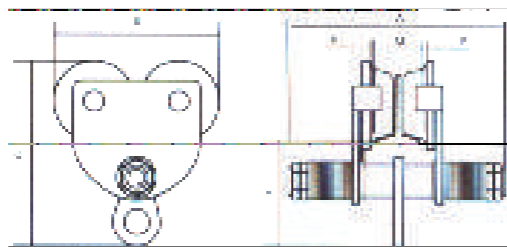

Model :GCT-A

Model	Capacity(t)	Compatible Rail Size(mm)		Plain Trolley GCT-A Specification									Min.rotation Radius(mm)	Net Weight (kg)
		Width(W) Min.	Max.	Height(H) Min.	Max.	A	B	C	D	E	F	K		
GCT-A05	0.5	75	125	100	150	206	174	120	Φ45	Φ55	27	-	900	6.0
GCT-A10	1	75	125	125	250	206	231	120	Φ45	Φ80	27	-	1300	10.0
GCT-A20	2	100	150	150	400	241	271	155	Φ60	Φ100	33	-	1500	18.5
GCT-A30	3	100	150	180	400	261	311	185	Φ70	Φ113	47	-	2000	26.0
GCT-A50	5	125	175	250	450	294	351	220	Φ80	Φ125	53	-	2600	44.0
GCT-A100	10	150	175	250	450	291	721	165	-	Φ125	53	-	-	96.0

MANUAL GEAR TROLLEY

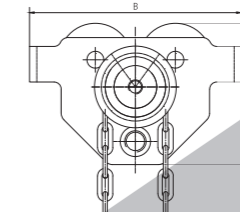
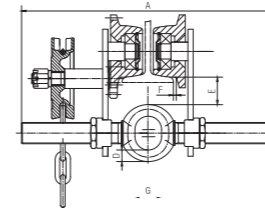

Model :GCL-C

MANUAL GEAR TROLLEY (MODEL: GCL-C)

Model	t	TGT-005	TGT-010	TGT-020	TGT-030	TGT-050	TGT-100*	TGT-200*	TGT-300*
Capacity	t	0.5	1	2	3	5	10	20	30
Proof Load	t	0.75	1.5	3	4.5	7.5	12.5	25	37.5
I-Beam Width	mm	50-220	58-220	66-220	74-220	90-220	125-203	136-203	144-250
Dimensions (mm)	A	352.5	353.5	362	406.5	434.5	487.5	523	570
	B	198	238	277	324	373	455	642	642
	C	158	183	208	249	296.5	490	622	622
	D	12.5	17	20	26	28	82	110	110
	E	40	31	31	31	40	36.5	54	50
	F	≈3	≈3	≈3	≈3	≈5	≈5	≈5	≈5
	G	25	29	36	46	52			
Net Weight	kg	8.5	12.5	17	28	45	93	247.5	254

MANUAL PUSH TROLLEY

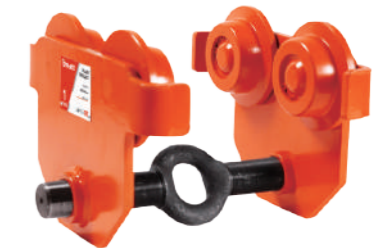
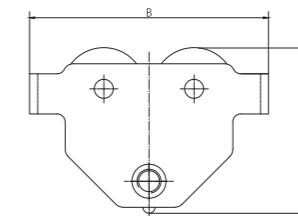
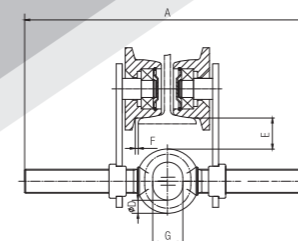

Model :GCT-C

MANUAL PUSH TROLLEY (MODEL: GCT-C)

Model	t	TPT-005	TPT-010	TPT-020	TPT-030	TPT-050
Capacity	t	0.5	1	2	3	5
Proof Load	t	0.75	1.5	3	4.5	7.5
I-Beam Width	mm	50-220	58-220	66-220	74-220	90-220
Dimensions (mm)	A	285	300	300	328	354
	B	198	238	277	324	373
	C	158	183	208	249	296.5
	D	12.5	17	20	26	28
	E	40	31	31	31	40
	F	≈3	≈3	≈3	≈3	≈5
	G	25	29	36	46	52
Net Weight	kg	5	8.8	14	23	40



LIFTING CLAMP PLATE HORIZONTAL

**WORKING LOAD LIMIT (WLL)
800 - 16000 kgs.**

- The PDB Horizontal Plate clamps are suitable for lifting and transport of steel plates.
- Construction and profiled bar in horizontal position.
- Manufactured from high quality carbon steel.
- Avoid snatch re shock load the screw jaw of the body can be changed, also have a safety button.



Model :PDB

NB : The top angle between the chain / rope legs must not exceed 45 degree from vertical.



EUROPE MODEL
Suitable for lifting and horizontal transfer of steel plates structures.



SOLID BODY
Made of High - quality Low - carbon alloy steel with a safety button.

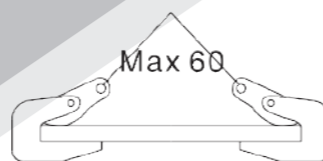
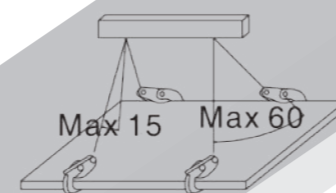
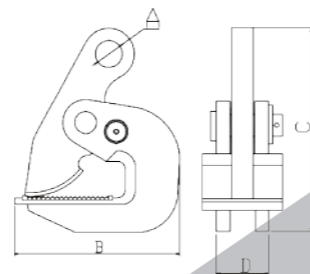

model	Jaw Opening [mm]	Load Capacity [kg/par]	A (mm)	B (mm)	C (mm)	D (mm)	Weight (kg)
PDB 0.8	0-25	800	22	125	165	40	2.5
PDB 1	0-30	1000	25	148	205	40	3.5
PDB 1.6	0-30	1600	30	148	205	45	4
PDB 2	0-40	2000	30	172	245	47	5
PDB 3.2	0-45	3200	30	180	245	50	6
PDB 4	0-50	4000	30	170	260	52	6.5
PDB 5	0-55	5000	30	180	260	56	7.5
PDB 6	0-65	6000	37	210	308	62	10.5
PDB6B	0-130	6000	37	316	310	62	22
PDB 8	0-100	8000	55	400	400	65	22
PDB 10	0-125	10000	55	500	500	75	33
PDB 16	100-180	16000	60	410	690	90	51

LIFTING CLAMP PLATE VERTICAL

WORKING LOAD LIMIT (WLL) 800 - 30000 kgs.

- Standard design clamp for vertical lifting of steel plates and steel structures.
- The spring - loaded tightening lock mechanism assures a positive initial clamping force.
- Clamps are equipped with a safety mechanism, ensuring the clamp does not slip when lifting force is applied and when load is being lowered.
- High - frequency quenching of die - forged special alloy steels gives greater durability to the cam.



Model :CDH

NB : The plate surface of the material must a hardness level below HRC30 / Brinell 300



JAPAN MODEL
Suitable for lifting and vertical transfer of steel plates structures.



SOLID BODY
Made of High - quality Low - carbon alloy steel with a safety puller.

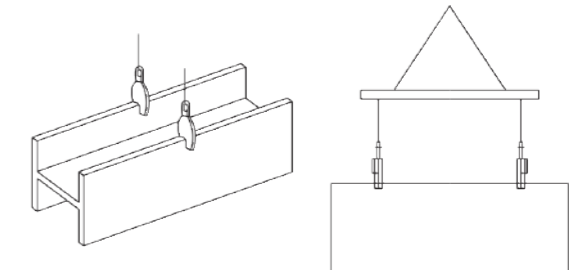

RACHET STRAP

Model	WLL(tonnes)	Jaw Opening(mm)	Weight(kg)
CDH-B 0.8	0.8	0-16	2.8
CDH-B 1	1	0-22	3.6
CDH-B 2	2	0-30	5.5
CDH-B 3.2	3.2	0-40	10
CDH-B 5	5	0-50	17
CDH-B 8	8	0-60	26
CDH-B 10	10	0-80	32
CDH-B 12	12	25-90	48
CDH-B 16	16	60-125	80
CDH-B 30	30	80-220	125

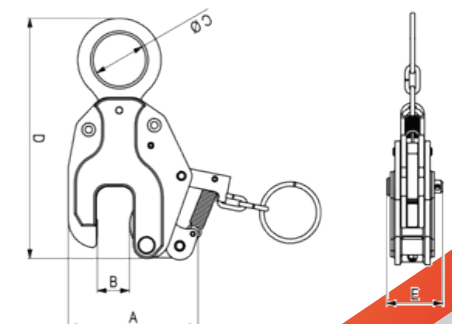



PLUS HORIZONTAL LIFTING CLAMP

- This LC clamp is used for horizontal lifting and transfer of steel. Working fields plates and is particularly suited to this application due to the special thing round plate and buffer cams which facilitate easy insertion and removal under the plate being lifted. It can also be used hanging vertically under a spreader.
- These clamps are light in weight relative to their lifting capacity.
- Please note that the WLL of these clamps is given based on apai.
 - 1.At building construction field
 - 2.At shipbuilding field for surface hardness esupto37RC(345HB) .
 - 3.Metal production workshop
 - 4.At subway construction(civil engineering construction) sites



Model :LC

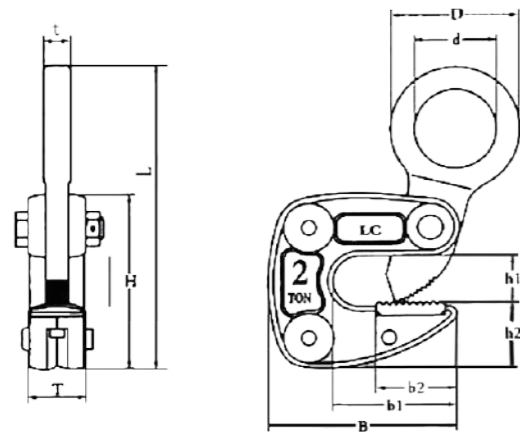

- Safety technical features
 1. Embossed branding, Pcode for good trace ability and quality guarantee.
 2. All forged parts with stock availability at anytime
 3. High strength and durability with MBL of 500% of capacity, or better.

Jaw and floor Material: 35Cr Mu Ti Meets standard BS EN 13155

Item No.	WLL (t/pair)	Opening (mm)	L	t	T	Dimensions(mm)					d	Weight (kg)		
						H	h1	h2	B	b1			b2	
LC1	1	1~13	166	12	32	100	22	36	102	64	42	70	46	2.1
LC2	2	3~22	235	16	40	132	33	46	130	84	56	92	56	4.7
LC3	3	12~35	276	18	44	178	40	66	172	92	70	82	42	8.4

PLATE LIFTING CLAMP

Technical Specialities

- The universal vertical CD clamp is designed to ensure that the load can be lifted and turned(180°) .Whilst at the same time ensuring that the load is positively retained.
- These clamps have a wide range of uses and are particularly suited for the lifting and turning of steel plates, ship sections and the extraction of pile sheets.

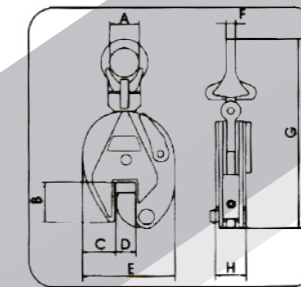

Model :CD



- The clamp is fitted with a safety latch which ensures the proper use by means of a double locking device, both in open as well as closed position.
- This also guarantees a pre-load on the material being lifted.

Model	WLL (tonnes)	Jaw Opeing (mm)	Weight (kg)
CD0.8	0.8	0-15	2
CD1	1.0	0-15	4
CD1(B)	1.0	0-20	5
CD1.6	1.6	0-20	7
CD2	2.0	0-25	8
CD3.2	3.2	0-25	15
CD3.2(B)	3.2	0-30	15
CD5	5.0	0-30	21
CD5(B)	5.0	0-50	23
CD8	8.0	0-45	37
CD12	12.0	0-70	50
CD16	16.0	60-100	65
CD30	30.0	60-220	120



BEAM CLAMP

- Provides a quick and versatile rigging point for hoisting equipment, pulley blocks or loads.
- Flexible application due to wide adjustment range.
- The central threaded spindle allows easy attachment and a safe and secure grip.
- The spindle can be secured against loosening.
- Fits wide range of beams and flange widths, low headroom design.
- Widely option for flange width.



Model :JG

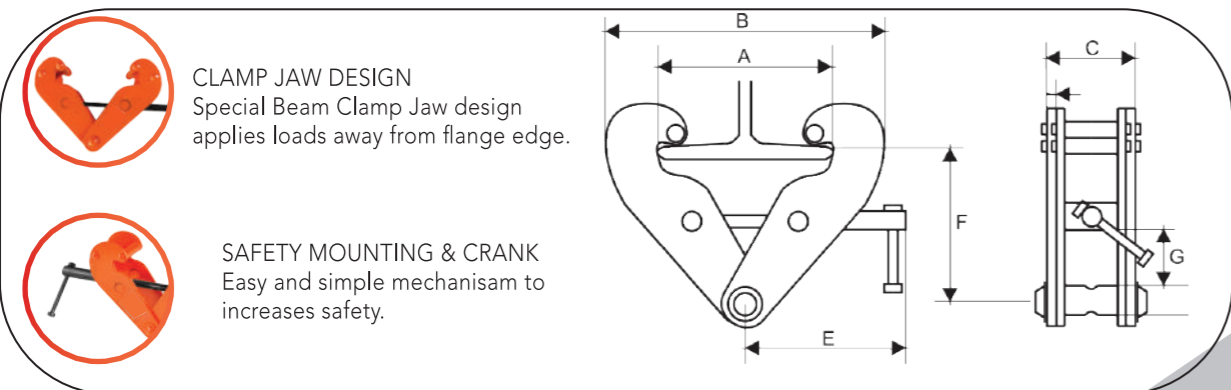

Model	Capacity Load [t]	Test Load [kn]	I-Beam Width Range(mm)	A Max	B		C	E	F		G	Net weight (kg)
					Min	max			Min	max		
JG-1	1	12.3	75-220	260	180	360	64	215	102	155	25	3.8
JG-2	2	24.5	75-220	260	180	360	74	215	102	155	25	4.6
JG-3	3	36.8	80-320	354	235	490	103	260	140	225	45	9
JG-5	5	61.3	80-320	354	235	490	110	260	140	225	45	11
JG-10	10	122.5	90-320	365	320	505	120	280	170	235	50	16

DRUM LIFTER

- Provides a quick and versatile rigging point for hoisting equipment, pulley blocks or loads.
- Flexible application due to wide adjustment range.
- Widely option for flange width.



CLAMP JAW DESIGN
Special Beam Clamp Jaw design applies loads away from flange edge.



SAFETY MOUNTING & CRANK
Easy and simple mechanism to increases safety.



Model :CDLP



Model :CDL



Model :CDLB



TECHNICAL SPECIFICATION

Model	Capacity (kg)	Chain Size (mm)	Length of lift chain (mm)	Net weight / New (kg)
CDLB	1000	6×18	500	3.6 / 5.38
CDLP	1000	7×21	500	5.6
CDL	1000	6×18	500	3.6



PDQ SINGLE STEEL PLATE CLAMP

- Suitable for lifting and transport single or multi steel plates.
- Manufactured from high quality carbon steel.
- Avoid snatch or shock loading. Lifting beam must be in use.
- The roller at the head of the hook will not damage the sling rope.
- The working load limit is the maximum load that the clamps are authorized to support when used in pairs with a lift angle of 60°.
- In lifting operations four clamps must at least always be used. Automatic unloading.



Model : PDQ

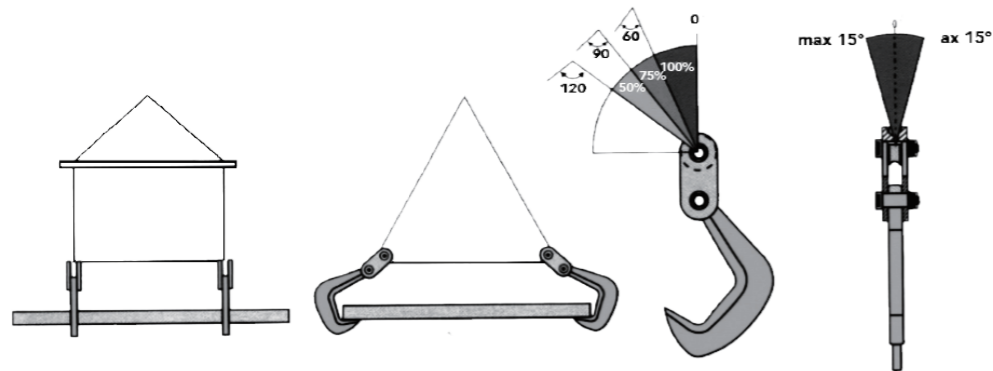

Model	WLL (tonnes)	Jaw Opening (mm)	Weight (kg)
PDQ 1	1.0	0-50	3
PDQ 2	2.0	0-60	5
PDQ 3.2	3.2	0-90	12
PDQ 5	5.0	0-120	17
PDQ 8	8.0	0-130	25
PDQ 10	10.0	0-150	30
PDQ 12	12.0	0-150	32
PDQ 20	20.0	0-250	69

TPH PIPE PLATE CLAMP

- For horizontal lifting and transporting of steel and concrete pipes.
- Compact shapes and relatively low own weight with a high lifting capacity.
- The surface is equipped with "special" plastic.
- The TPH will be delivered per pair.
- Plastic cover is easy to change.



Model : TPH

TECHNICAL PARAMETERS

Model	WLL (tonnes)	Jaw Opening (mm)	Weight (kg)
TPH 1.5	1.5	40	1.5
TPH 3	3.0	40	2
TPH 4	4.0	50	2.8
TPH 6	6.0	50	3.2
TPH 8	8.0	70	5
TPH 12	12.0	70	13
TPH 16	16.0	70	15.8
TPH 18	18.0	70	22



Model : PCT

PALLET CLAMP

- The pallet pullers are used to pull loaded pallets, slide heavy crates, etc., to edge of dock or truck, so it can be picked up with forklift truck.
- Variable jaw width grabs pallet securely and automatically releases.

Item No.	PCT10	PCT15	PCT20	PCT25
Capacity(t)	1	1.5	2	2.5
Beam width(mm)	30~100	30~180	30~200	30~135
Dimensions(mm)	A max	412	520	552
	A min	260	310	340
	B max	310	335	390
	B min	258	245	310
	C	12	86	86
	D	16	20	20



PERMANENT MAGNET LIFTER

MAIN USAGE AND CHARACTERISTICS

- The permanent magnet lifter of PML Series is mainly used to magnetism plant shape or column ironware materials and workpiece.
- It is provided with the characteristics of light structure, easy operation and powerful magnetism.
- It has been widely used as the hoisting tool in factory, dock storehouse and transportation.



Model :PML



WORKING PERFORMANCE

Stable and lasting working performance magnet lifter.



SAFETY FACTOR

High safety factor, strong pull - off - strength and strong permanent magnet circuit.

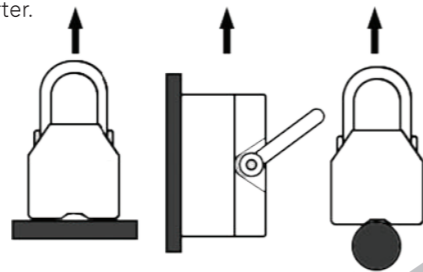

Type	Rated Lifting weight(kg)	Max pulling power(kg)	Dimension(mm)				Net weight(kg)
			L	B	H	R	
PML-100	100	300	135	63	75	160	3
PML-200	200	600	170	67	80	160	4
PML-300	300	900	190	92	94	215	10
PML-400	400	1200	190	92	94	215	10
PML-600	600	1800	240	120	115	240	20
PML-1000	1000	3000	300	136	138	270	35
PML-2000	2000	6000	390	160	168	368	65
PML-3000	3000	9000	480	160	168	368	82
PML-5000	5000	15000	570	230	220	490	200

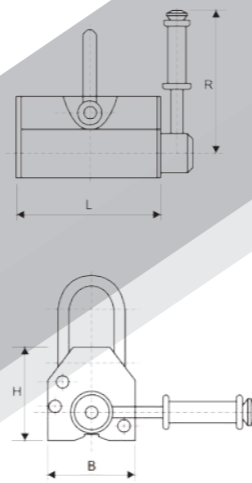

SBH CHAMPION SNATCH PULLEY (hook Type)



Model :SBH

Model	S.W.L (t)	Sheave Dia D(mm)	A2 (mm)	B (mm)	C (mm)	For Wire Dia (mm)	N.W. (kg)
SBH- 3"x 1	2	75	292	82	70	7-9	4
SBH- 4-1/2"x 1	4	115	358	120	70	10-12	6.1
SBH- 6"x 1	4	150	412	160	70	16-18	13.8
SBH- 6"x 1	8	150	498	160	93	20-22	14.4
SBH- 8"x 1	8	200	549	210	93	20-22	16
SBH- 8"x 1	15	200	672	230	102	22-24	24
SBH-10"x 1	10	250	695	260	115	24-26	37.5
SBH-10"x 1	12	250	701	260	115	24-26	42
SBH-12"x 1	12	300	797	310	133	24-26	56
SBH-12"x 1	15	300	797	310	133	26-26	65
SBH-14"x 1	22	355	960	365	140	28-32	90
SBH-16"x 1	22	400	1027	415	140	28-32	108
SBH-16"x 1	30	400	1085	415	155	32-35	135
SBH- 20"x 1	30	500	1177	514	162	32-35	210
SBH- 24"x 1	50	600	1445	625	240	46-50	408

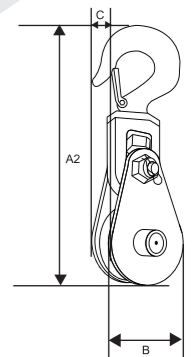

SBS CHAMPION SNATCH PULLEY (shackle Type)

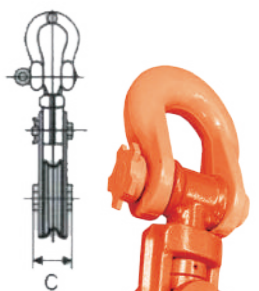
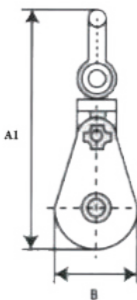

Model :SBS

SPECIFICATIONS

Model	S.W.L (t)	Sheave Dia D(mm)	A1 (mm)	B (mm)	C (mm)	For Wire Dia (mm)	N.W. (kg)
SBS- 3"x 1	2	75	286	82	70	7-9	4
SBS- 4-1/2"x 1	4	115	345	120	70	10-12	6.1
SBS- 6"x 1	4	150	399	160	70	16-18	13.8
SBS- 6"x 1	8	150	475	160	93	20-22	14.4
SBS- 8"x 1	8	200	528	210	93	20-22	16
SBS- 8"x 1	15	200	663	230	102	22-24	24
SBS-10"x 1	10	250	679	260	115	24-26	37.5
SBS-10"x 1	12	250	679	260	115	24-26	42
SBS-12"x 1	12	300	767	310	133	24-26	56
SBS-12"x 1	15	300	884	310	133	26-26	65
SBS-14"x 1	22	355	952	365	140	28-32	90
SBS-16"x 1	22	400	1019	415	140	28-32	108
SBS-16"x 1	30	400	1126	415	155	32-35	135
SBS- 20"x 1	30	500	1256	514	162	32-35	210
SBS- 24"x 1	50	600	1525	625	240	46-50	408



FORGED LEVER LOAD BINDER

- Made from quenched and tempered alloy steel.
- Extra heavy construction at leverage point to prevent spreading heel of binder toggles away from load, permitting easy release.
- Ball and socket swivel joints at hook assemblies permit a straightline pull

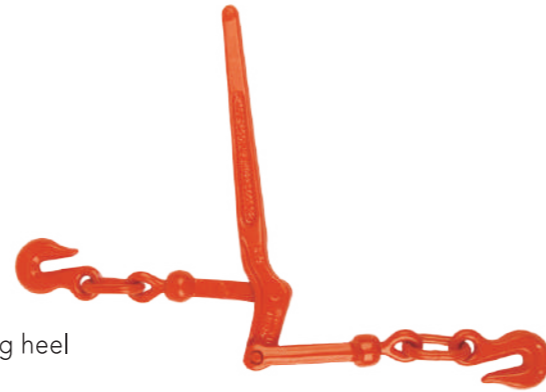

Model :LLB

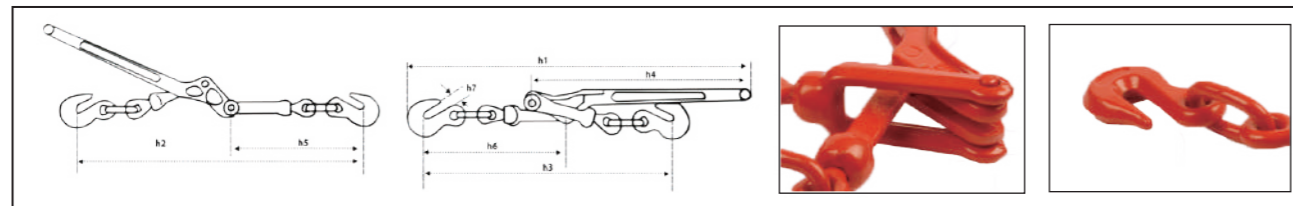

SPECIFICATIONS

Min-Max chain size (in.)	WLL (lbs)	Proof load (lbs)	Min ultimate load (lbs)	Weight (lbs)	Handle length (in.)	Dimensions(in.)						
						H1	H2	H3	H4	H5	H6	H7
1/4-5/16	2600	5200	7800	3.52	11.42	18.5	17.3	14.17	11.42	8.27	8.07	0.35
5/16-3/8	5400	10800	19000	8.37	15.43	25.2	23.2	19.49	15.55	11.22	11.22	0.51
3/8-1/2	9200	18400	28000/33000	12.11/12.20	17.24	28.5	26.38	22.05	17.64	12.99	12.20	0.59
1/2-5/8	11000	22000	44000	19.7	21.00	33.86	30.12	25.78	20.87	14.37	14.37	0.74

FORGED RATCHET LOAD BINDER

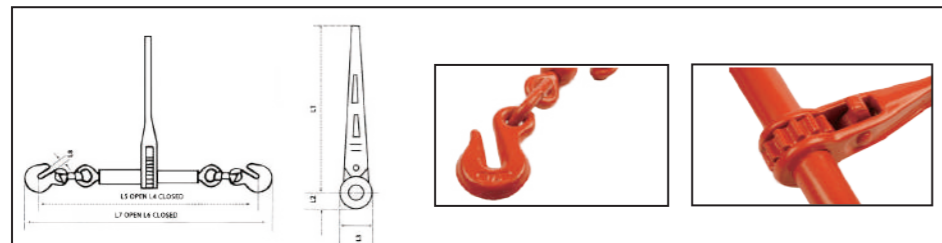

Model :RLB

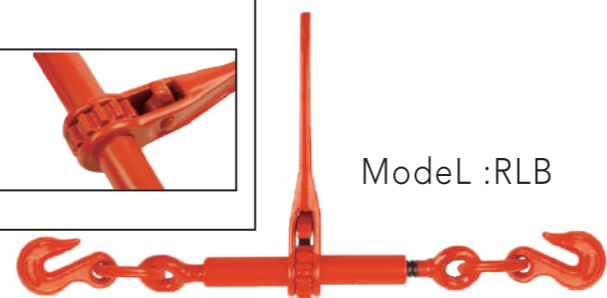

SPECIFICATIONS

Min-max chain size (in.)	WLL (lbs)	Proof load (lbs)	Min ultimate load (lbs)	Weight (lbs)	Handle length (in.)	Dimensions(in.)							
						L1	L2	L3	L4	L5	L6	L7	L8
1/4-5/16	2600	5200	7800	3.52	7.16	7.16	0.89	1.77	16.22	21.26	17.79	22.83	0.35
5/16-3/8	5400	10800	19000	10.50	13.42	13.92	1.30	2.60	22.64	30.64	25.25	33.24	0.51
3/8-1/2	9200	18400	33000	12.90	13.92	13.92	1.30	2.60	24.13	32.13	27.04	33.04	0.59
1/2-5/8	13000	26000	46000	14.38	13.92	13.92	1.30	2.60	26.45	34.45	30.07	38.07	0.74

FORGED D-RINGS WITH WRAPS

- Material: Forged superalloy steel.
- 100% magna flux crack detection.
- Breakage test.
- Welding is to be performed by a qual fied welder.



Stock No.	Dimensions(mm)					W.L.L.(T)	Weight(KG)
	A	B	D	H	M		
TLDRW0112	41.0	78.0	13.0	30.0	37.0	1.12	0.40
TLDRW0200	42.0	88.0	14.0	33.0	40.0	2	0.48
TLDRW0315	45.0	94.0	17.0	35.0	42.5	3.15	0.69
TLDRW0530	55.0	118.0	22.0	47.5	51.0	5.3	1.50
TLDRW0800	70.5	140.0	26.0	56.5	65.0	8	2.50
TLDRW1000	85.0	165.0	30.0	70.0	90.0	10	4.25
TLDRW1500	98.0	189.0	34.0	77.0	90.0	15	5.79
TLDRW2000	147	278	46.0	85.0	121	20	15.1

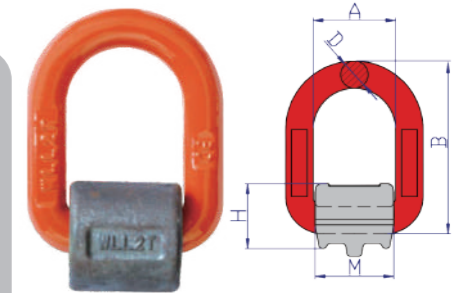

Model :DRW

Muti -Directional Using Lifting Swivel

Stock No.	Size DxE	Dimensions(mm)						W	Ø	W.L.L.(T)		Weight(KG)
		A	B	C	G	T	90°			0°		
TLDLS0813	M8x13	55.0	36.0	15.5	52.0	44.0	30.0	13.0	0.3	0.6	0.43	
TLDLS1019	M10x19	55.0	36.0	15.5	52.0	44.0	30.0	13.0	0.45	0.9	0.45	
TLDLS1219	M12x19	55.0	36.0	15.5	52.0	44.0	30.0	13.0	0.5	1	0.46	
TLDLS10318	M12x31.8	55.0	36.0	15.5	52.0	44.0	30.0	13.0	0.5	1	0.47	
TLDLS1422	M14x22	55.0	36.0	15.5	52.0	44.0	30.0	13.0	1.12	2	0.48	
TLDLS14318	M14x31.8	55.0	36.0	15.5	52.0	44.0	30.0	13.0	1.12	2	0.49	
TLDLS16318	M16x31.8	55.0	36.0	15.5	52.0	44.0	30.0	13.0	1.12	2	0.50	
TLDLS2030	M20x30	85.0	60.0	22.5	81.0	69.0	40.0	18.0	2	4	1.57	
TLDLS20318	M20x38.1	85.0	60.0	22.5	81.0	69.0	40.0	18.0	2	4	1.58	
TLDLS2230	M22x30	85.0	60.0	22.5	81.0	69.0	40.0	18.0	2	4	1.58	
TLDLS22381	M22x38.1	85.0	60.0	22.5	81.0	69.0	40.0	18.0	2	4	1.59	
TLDLS2430	M24x30	85.0	60.0	22.5	81.0	69.0	40.0	18.0	3.15	6.3	1.61	
TLDLS24381	M24x38.1	85.0	60.0	22.5	81.0	69.0	40.0	18.0	3.15	6.3	1.62	
TLDLS2735	M27x35	85.0	60.0	22.5	81.0	69.0	40.0	18.0	3.15	6.3	1.62	
TLDLS3035	M30x35	115.0	80.0	26.5	110.0	90.0	50.0	25.0	5.3	10.6	3.72	
TLDLS3050	M30x50	115.0	80.0	26.5	110.0	90.0	50.0	25.0	5.3	10.6	3.75	
TLDLS3335	M33x35	115.0	80.0	26.5	110.0	90.0	50.0	25.0	8	11.8	3.75	
TLDLS3350	M33x50	115.0	80.0	26.5	110.0	90.0	50.0	25.0	8	11.8	3.77	
TLDLS3654	M36x54	115.0	80.0	26.5	110.0	90.0	50.0	25.0	8	11.8	3.81	
TLDLS3958	M39x58	115.0	80.0	26.5	110.0	90.0	50.0	25.0	8	8	3.86	

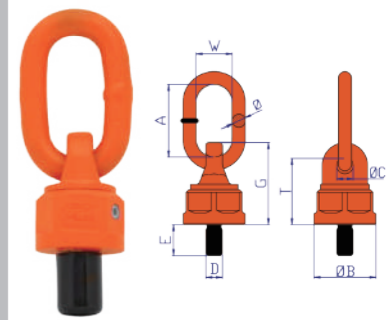

Model :DLS



CHAIN AND CHAIN SLING

- Alloy chain is designed and manufactured for superior performance and usage. It can easily withstand more abuse, abrasion resistance, greater load lifting per size and is lighter to handle for application.
- Alloy steel Material, heat treated and proof tested

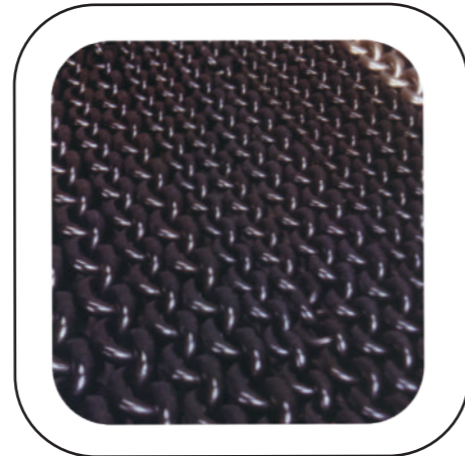
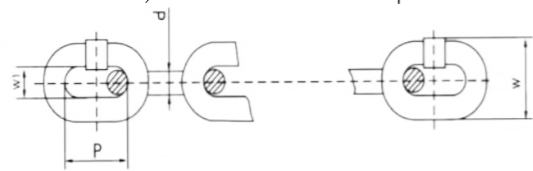

Model :AW

Item No.	Chain Dia. p (mm)	Inside Length P (mm)	Alloy Chain GR80		WLL(t)	Ultimate Load(t)	Weight Approx(kg)
			Outside Width W (mm)	Inside Width W1 (mm)			
AW-80-05	5	15.00	16.25	6.80	0.65	2.60	0.50
AW-80-06	6	18.00	19.50	8.00	1.00	4.00	0.80
AW-80-063	6.3	19.80	21.50	8.50	1.41	5.00	0.84
AW-80-07	7	21.00	22.75	9.00	1.41	5.00	1.10
AW-80-071	7.1	21.30	24.00	9.30	1.60	6.40	1.15
AW-80-08	8	24.00	26.00	10.00	2.00	8.00	1.40
AW-80-09	9	27.00	29.25	12.20	2.50	10.00	1.82
AW-80-10	10	30.00	32.50	13.30	3.20	12.80	2.20
AW-80-112	11.2	34.00	36.00	13.70	3.80	15.20	2.70
AW-80-13	13	39.00	42.25	17.50	5.00	20.00	3.70
AW-80-16	16	48.00	52.00	21.50	8.00	32.00	5.60

- Original Germany WAFIOS Knitting, Spot welding calibrating and heat treatment machines and facilities are used for our daily production.

Item No.	Chain Dia.		Inside length (mm)	SUPER HIGH STRENGTH CHAIN GR100		WLL(t)	Ultimate load(t)	Weight Approx(kg)
	mm	in.		Outside width (mm)	Inside width (mm)			
AW-100-05	5	0.20	15.00	16.25	10.00	0.65	3.25	0.53
AW-100-06	6	0.24	18.00	19.50	12.00	1.00	5.00	0.85
AW-100-08	8	0.31	24.00	26.00	16.00	2.00	10.0	1.46
AW-100-10	10	0.39	30.00	32.50	20.00	3.20	16.0	2.30
AW-100-13	13	0.51	39.00	42.25	26.00	5.00	25.0	3.82

GUIDE FOR SAFER AND LONGER USE OF SLING

Do

- Do select right capacity slings including angles of sling leg.
- Do ensure that the chain slings are not kinked and twisted.
- Do lift uniformly the load in the multi-leg slings.

Do Not

- Do not expose the chain slings to excessive heat, as working load limit is affected by the heat higher than the temperature in the table.
- Do not drag the chain slings on the ground.
- Do not heat the chain slings.



Model :TDC

Chain Dia.(mm)	Tie Down chain GR80 type: TDC Length(ft.)	N.W.(kg)
7.1	9	3.3
8.0	9	4.2
10.0	9	6.5
13.0	9	10.8
7.1	18	6.3
8.0	18	8.5
10.0	18	13.2
13.0	18	21.6



Model :BC70

Size	Binder chain grade70 type: BC70									
	W.T.(kg)	ASTM80 WLL(ld)	MBS(ld)	W.T.(kg)	NACM90 WLL(ld)	MBS(ld)	W.T.(kg)	MACM96 WLL(ld)	MBS(ld)	Pes per drum
1 / 4 " × 14'	5.0	3,150	12,600	4.5	3,150	12,100	4.5	3,150	12,600	50
1 / 4 " × 16'	6.0	3,150	12,600	5.0	3,150	12,100	5.0	3,150	12,600	40
5 / 16 " × 14'	7.5	4,700	18,800	7.0	4,700	18,800	7.0	4,700	18,800	35
5 / 16 " × 16'	8.5	4,700	18,800	8.0	4,700	18,800	8.0	4,700	18,800	30
5 / 16 " × 16'	9.5	4,700	18,800	9.0	4,700	18,800	9.0	4,700	18,800	30
5 / 16 " × 20'	10.5	4,700	18,800	10.0	4,700	18,800	10.0	4,700	18,800	25
5 / 16 " × 25'	13.0	4,700	18,800	12.0	4,700	18,800	12.0	4,700	18,800	20
5 / 16 " × 30'	15.5	4,700	18,800	14.5	4,700	18,800	14.5	4,700	18,800	20
3 / 8 " × 14'	10.5	6,600	26,400	9.5	6,600	24,700	10.0	6,600	26,400	25
3 / 8 " × 16'	12.0	6,600	26,400	11.0	6,600	24,700	11.5	6,600	26,400	20
3 / 8 " × 20'	15.0	6,600	26,400	13.5	6,600	24,700	14.5	6,600	26,400	20
3 / 8 " × 25'	18.5	6,600	26,400	16.5	6,600	24,700	18.0	6,600	26,400	15



BELT SLING

- This belt slings are woven webbing with master ring connectings and end fitting.
- The length can be made according to the customer' needs.
- The master rings include weldless alloy links ,weldless rings weldless sling links and master link assembly etc,connecting could be bow shackles and connecting links. You can choose any kind of hooks according to the lifted project.
- Lifting sling can be round sling or webbing sling,end fittings can be vairous hooks and other metal fittings.
- Standard satety factor: 4:1we can also produce SF5:1&6:1.



Model: BTS

WIRE ROPE SLING

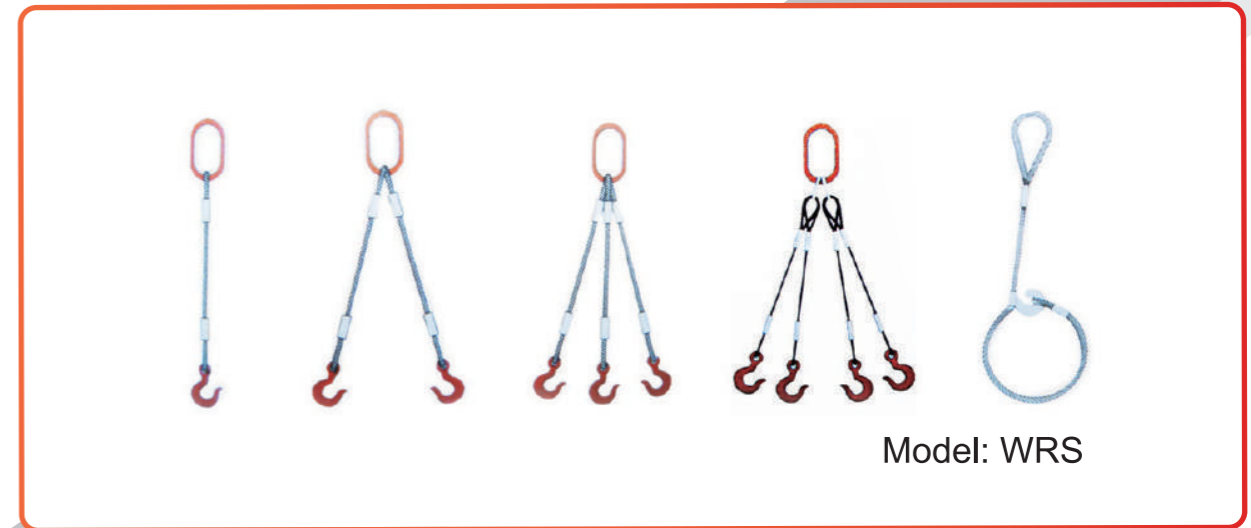

Model: WRS

CHAIN SLING

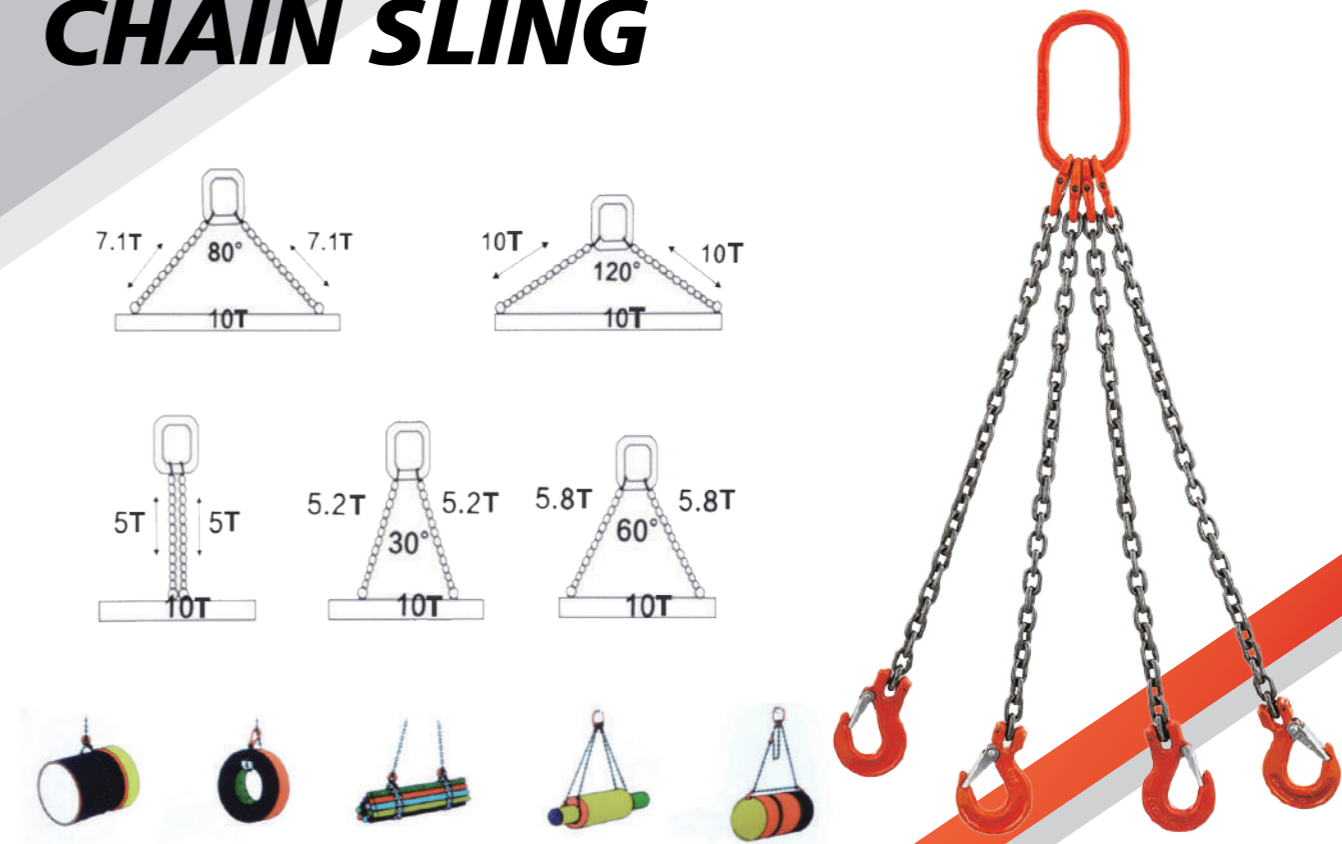

Model: CHS

	Color	$\beta=0$ to 45°	$\beta=0$ to 60°
	Purple	1000kg	
	Green	2000kg	
	Yellow	3000kg	
	Grey	4000kg	
	Red	5000kg	
	Purple	1400kg	1000kg
	Green	2800kg	2000kg
	Yellow	4200kg	3000kg
	Grey	5600kg	4000kg
	Red	7000kg	5000kg
	Purple	2100kg	1500kg
	Green	4200kg	3000kg
	Yellow	6300kg	4500kg
	Grey	8400kg	6000kg
	Red	10500kg	7500kg
	Purple	2100kg	1500kg
	Green	4200kg	3000kg
	Yellow	6300kg	4500kg
	Grey	8400kg	6000kg
	Red	10500kg	7500kg



ALLOY STEEL CONNECTING LINK

MASTER LINK

- High grade Alloy Steel (Quenched and Tempered) material
- Design Factor of 4: 1 for chain and 5: 1 for wire rope.
- Individually Proof Tested to 2.5 times the Working Load Limit(4: 1), unless otherwise noted, with certification.

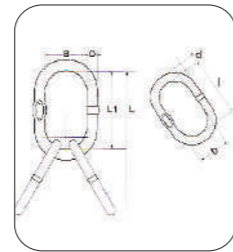

Model :MLA

Alloy Master Link Assembly Grade 80 Welding Type: MLA									
Product Code	Size D (mm)	Dimensions(mm)			WLL 4:1 (t)	Weight (kg)			
		L	L1	B			d	b	l
MLA-8-16	16	214	120	70	13	60	115	4.1	1.4
MLA-8-20	20	267	170	90	16	70	120	6.5	2.5
MLA-8-22	22	310	170	90	20	90	170	8.2	4.2
MLA-8-25	25	329	190	100	20	90	170	10.7	4.5
MLA-8-28	28	407	270	140	22	90	170	12.9	6.4
MLA-8-32	32	424	270	140	25	100	190	17.1	9.9
MLA-8-38	38	493	270	140	32	140	270	28.1	18.2
MLA-8-45	45	540	320	170	38	140	270	39.3	27.7

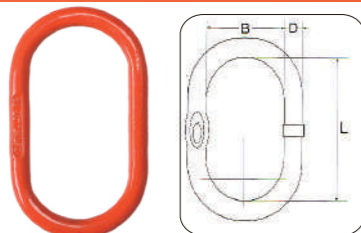

Model :MLW

- Each link has a Product Identification Code(PIC) for material traceability, along with the size and the manufacture mark.
- Larger inside width and length for use with thimble.

Alloy Master Link Grade 80 Welding Type: MLW					
Product Code	Size D (mm)	Dimensions(mm)		WLL 4:1 (t)	Weight (kg)
		L	B		
MLW-8-13	13	115	60	2.50	0.4
MLW-8-16	16	120	70	4.25	0.6
MLW-8-16A	16	170	100	4.25	0.80
MLW-8-20	20	170	90	6.70	1.30
MLW-8-22	22	170	90	8.20	1.60
MLW-8-22A	22	210	110	8.20	1.65
MLW-8-25	25	190	103	10.70	2.30
MLW-8-28	28	270	140	11.80	4.00
MLW-8-32	32	270	140	17.10	5.30
MLW-8-38	38	270	140	28.10	7.50
MLW-8-45	45	320	170	39.3	12.3

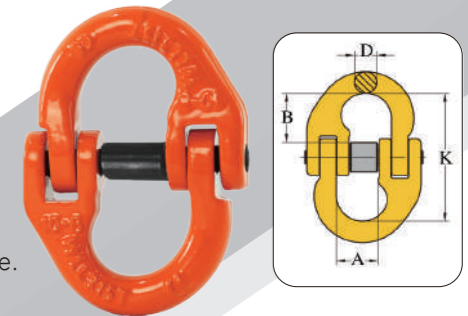

Model :LTC

- The C Link's simple design allows instant assembly, dismantling and reassembly of dependably safe slings.
- Assembly only one chain or fitting to each C link body half.
- When reassembly a C link we recommend you use a new pin and stud assembly. These are inexpensive and readily available.

Item No.	Working load limit(t)	For grade 80 chain(mm)	Alloy connecting link grade 80 type: LTC Dimensions(mm)				N.W. (kg)
			K	A	D	B	
LTC006	1.12	6	44	15	7	17	0.1
LTC007	2.0	7.8	59	18	9	22	0.2
LTC010	3.15	10	68	25	13	26	0.3
LTC013	5.3	13	91	30	16	35	0.7
LTC016	8.0	16	100	36	19	38	1.1
LTC018	12.5	18,20	122	42	23	48	1.7
LTC022	15.0	22	152	49	24	60	3.0
LTC026	21.2	36	162	55	31	62	4.6
LTC032	31.5	32	202	69	38	79	8.6

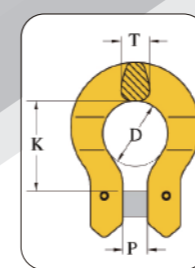

Model :LTO

- Rated for alloy chain Grade 80 and Grade100 for lifting application.
- Locking system that provides for simple assembly and disassembly-no special tools needed.
- Marked with brand, WLL, Batch No. and Size

Item No.	Working load limit(t)	For grade 80 chain(mm)	Alloy omega link grade 80 type: LTO Dimensions(mm)				N.W. (Kg)
			K	D	T	P	
LTO006	1.12	6	30	21	9	8	0.1
LTO007	2.0	7.8	36	27	11	9	0.2
LTO010	3.15	10	44	32	15	12	0.4
LTO013	5.3	13	55	42	17	16	1.0
LTO016	8.0	16	69	50	22	18	1.4
LTO018	12.5	18,20	71	58	28	20	2.3



ALLOY STEEL SAFETY HOOKS

LARGE HOOKS W/LATCH



- Breakage test.
- Ultimate load is 4 times working load limit.
- Fatigue tested at 1.5 times Working Load Limit for 20000 cycles.

Eye Safety Hook

Item No.	Size (mm)	Alloy Eye Safety Hook Grade 80 Type: HSE Dimensions(mm)								WLL 4:1 (t)	Weight (kg)
		L	A	B	D	E	F	G	H		
HSE006	6	107	28	28	70	22	10.5	16	22	1.2	0.5
HSE007	7	132	31	36	88	25	12	20	24	2.0	0.8
HSE010	10	164	48	41	106	32	15	26	30	3.2	1.5
HSE013	13	206	60	52	138	40.5	20	32	40	5.4	3.2
HSE016	16	249	73	60	170	55	23	40	51	8.2	6.1
HSE018	18	270	77	79	187	64	27	45	56	12.5	7.5
HSE022	22	310	90	88	204	70	30	52	65	15.0	13.4

Model : HSE

Eye Hook With Latch

Stock No.	Dimensions(mm)				W.L.L.(T)	Weight(KG)
	B	E	R	T		
UEH0125	19.0	20.0	81.0	19.0	1.25	0.26
UEH0160	22.5	22.0	90.5	20.5	1.6	0.41
UEH0250	27.0	27.0	105.0	27.0	2.5	0.61
UEH0320	32.0	32.0	123.5	30.0	3.2	0.98
UEH0540	39.0	37.0	147.0	37.0	5.4	1.68
UEH0800	50.0	48.0	190.0	48.0	8	3.63
UEH0115	64.0	53.0	230.0	53.0	11.5	6.72
UEH0160	70.5	60.0	25.0	60.0	16	10.04
UEH0220	89.0	77.0	3164.0	77.0	22	16.20

Model : UEH

Clevis Safety Hook

Item No.	Size (mm)	Alloy Clevis Safety Hook Grade 80 Type: HSC Dimensions(mm)										WLL 4:1 (t)	Weight (kg)
		L	A	B	C	D	E	F	G	H			
HSC006	6	95	31	26	7.8	70	8.5	32	16	22	1.2	0.45	
HSC007	7	117	39	36	9.2	89	9	37	20	24	2.0	0.85	
HSC010	10	140	52	44	13.2	107	12	47.5	26	30	3.2	1.45	
HSC013	13	176	65	52	16.3	139	15	60	32	40	5.4	2.90	
HSC016	16	210	75	63	20.2	168	18	73	40	51	8.2	5.60	
HSC018	18	232	83	76	24.3	186	25	81	45	56	12.5	6.50	
HSC022	22	265	88	80	28.2	204	25.5	98	52	65	15.0	16.00	

Model : HSC

Swivel Hook With Latch

Stock No.	Size(mm)	Dimensions(mm)								W.L.L.(T)	Weight(KG)
		A	E	B	H	K	L	M			
USH006	6	31.8	22.3	23.8	9.5	113.5	142.5	16.0	1.12	0.40	
USH008	8	44.5	25.4	41.3	15.9	152.8	195.7	21.0	2.0	1.03	
USH010	10	44.5	28.4	39.7	15.9	161.9	207.9	23.0	3.15	1.29	
USH013	13	50.8	34.0	44.5	19.1	188.1	244.2	28.0	5.3	2.33	
USH016	16	63.5	42.9	58.7	25.4	243.7	315.7	35.5	8.0	4.72	
USH020	20	69.9	52.2	60.3	28.6	282.6	368.4	41.0	12.5	7.37	
USH022	22	79.4	57.0	71.4	31.8	303.2	403.7	56.5	15.0	10.63	
USH026	26	105.0	81.0	114.0	40.0	431.0	546.0	69.0	21.2	21.40	
USH032	32	105.0	82.5	105.0	40.0	472.0	596.0	76.2	31.5	32.00	

Model : USH

Swivel Safety Hook

Item No.	Working Load Limit(t)	For Grade 80 Chain(mm)	Alloy Swivel Safety Hook Type: HSA Dimensions(mm)								N.W. (kg)
			K	P	B	A	D	T	H		
HSA006	1.12	6	149	29	22	31	12	15	21	0.6	
HSA007	2.0	7.8	186	34	29	36	14	20	25	1.1	
HSA010	3.15	10	220	44	34	40	16	26	31	2.0	
HSA013	5.3	13	267	52	43	46	22	34	40	4.0	
HSA016	8.0	16	328	60	52	60	24	41	52	6.8	
HSA018	12.5	18,20	388	90	82	75	26	48	62	11.6	
HSA022	15.0	22	457	80	95	97	33	49	63	16.0	

Model : HSA

Container Hook

Stock No.	Size(mm)	Dimensions(mm)						W.L.L.(T)	Weight(KG)
		B	L	E	E1	R	Ø		
UCH006	6	26.5	149.0	47.0	39.0	83.5	24.0	2	0.68
UCH008	8	35.5	179.0	49.0	40.0	95.0	30.0	3	1.38
UCH010	10	38.5	198.0	54.0	45.0	105.5	33.5	5	1.72
UCH013	13	52.0	250.0	69.5	61.0	127.5	43.0	8	3.50

Model : UCH



ALLOY STEEL GRAB HOOK

- Material is highgrade alloy steel(quenched and tempered).
- Used with alloy chain Grade 80 for lifting application.
- Marked with Brand, WLL, Batch No.and Size.
- 100% 4 times of capacity proof load tested.
- Ulimtate load is 7 times of capacity.



Chain Size(in.)	Stock No.	WLL(lbs)	Weight Each (lbs)	Alloy Eye Grab Hook Type: A-323											
				Dimensions(in.)											
				A	B	C	D	E	G	K	L	N	R		
1/4	1132384	3500	0.28	1.09	0.53	0.31	1.81	0.34	0.88	0.47	3.05	1.75	1.88		
5/16	1132400	4700	0.45	1.31	0.62	0.38	2.12	0.44	0.97	0.59	3.59	2.06	2.28		
3/8	1132428	7100	0.79	1.56	0.75	0.44	2.53	0.50	1.17	0.72	4.28	2.34	2.69		
1/2	1132464	12000	1.75	1.94	0.88	0.53	3.56	0.66	1.53	0.78	5.44	2.97	3.28		
5/8	1132482	15800	3.25	2.38	1.06	0.66	4.39	0.78	1.78	1.09	6.66	4.31	4.11		
3/4	1132507	24700	5.94	2.88	1.38	0.75	5.22	0.94	2.13	1.31	8.06	5.09	5.16		

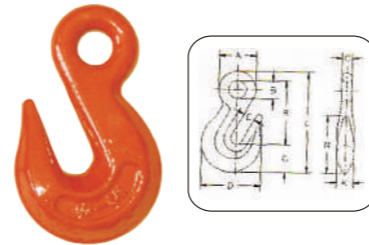

Model :A-323

Chain Size(in.)	Stock No.	WLL(lbs)	Weight Each (lbs)	Alloy Clevis Swivel Grab Hook Type: A-330											
				Dimensions(in.)											
				A	B	C	D	E	G	H	K	L	N	P	R
1/4	1123249	3500	0.36	1.00	0.32	0.31	1.81	0.34	0.88	0.72	0.47	3.05	1.75	0.31	1.64
5/16	1123267	4700	0.62	1.22	0.43	0.36	2.12	0.44	0.97	0.91	0.59	3.66	2.06	0.38	2.02
3/8	1123285	7100	1.00	1.42	0.48	0.49	2.53	0.50	1.17	1.00	0.72	4.42	2.34	0.44	2.41
7/16	1123301	8750	1.31	1.66	0.66	0.62	3.09	0.56	1.31	1.13	0.69	4.94	2.66	0.56	2.75
1/2	1123329	12000	2.22	1.88	0.57	0.51	3.56	0.66	1.53	1.25	0.78	5.72	2.97	0.63	3.19
5/8	1123347	15800	4.41	2.31	0.71	0.67	4.39	0.78	1.78	1.56	1.09	6.83	4.31	0.75	4.09
3/4	1123365	24700	6.50	2.62	0.94	0.94	5.22	0.94	2.13	1.88	1.31	8.13	5.09	0.88	4.63

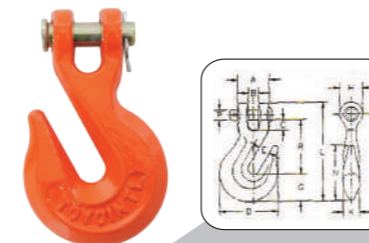

Model :A-330

Eye Sling Hook With Latch

Stock No.	Size(mm)	Dimensions(mm)					W.L.L.(T)	Weight(KG)
		D	E	L	I	Ø		
ESH006	6	32.4	25.0	107.0	9.0	20.0	1.12	0.30
ESH008	7/8	37.2	30.0	131.5	10.5	25.0	2.0	0.55
ESH010	10	43.8	32.5	167.0	16.0	38.0	3.15	1.15
ESH013	13	55.0	37.0	213.0	19.5	42.5	5.3	2.32
ESH016	16	68.9	42.0	256.0	23.0	50.0	8.0	3.45
ESH020	20	87.4	51.0	305.0	27.0	61.0	12.5	6.60
ESH022	22	98.0	72.0	344.0	33.0	68.3	15.0	8.50
ESH026	26	112.5	85.0	392.5	34.5	63.0	21.2	13.00
ESH032	32	140.0	106.0	480.5	37.0	88.0	31.5	17.00

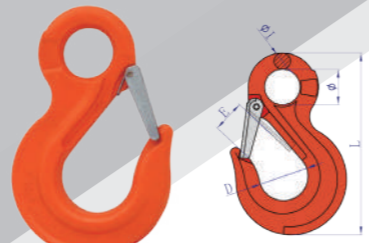

Model :ESH

CLEVIS SHORTENING GRAB HOOK

Stock No.	Size(mm)	Dimensions(mm)				W.L.L.(T)	Weight(LBS)
		A	E	H	L		
EGH006	6	8.0	8.0	18.5	76.5	1.12	0.12
EGH008	7/8	9.5	11.0	21.0	90.7	2	0.32
EGH010	10	12.5	13.5	29.5	124.5	3.15	0.78
EGH013	13	15.3	17.0	42.0	160.5	5.3	1.65
EGH016	16	19.5	20.0	44.0	182.0	8	2.86
EGH020	20	24.0	24.0	54.8	215.7	12.5	5.05
EGH022	22	27.0	28.0	67.5	252.0	15	6.32
EGH026	26	30.0	30.0	78.5	304.5	21.2	14.50

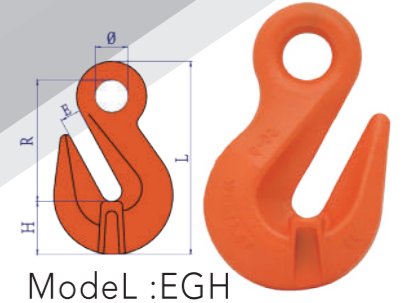

Model :EGH

Stock No.	Size(mm)	Dimensions(mm)					W.L.L.(T)	Weight(LBS)
		R	H	E	Ø	L		
CGH006	6	49.2	18.5	8.0	13.5	76.0	1.12	0.17
CGH008	8	60.0	21.0	11.0	17.0	90.3	2	0.25
CGH010	10	78.0	29.0	13.2	20.0	120.0	3.15	0.65
CGH013	13	98.0	42.8	16.5	26.0	156.0	5.3	1.39
CGH016	16	106.5	43.5	19.4	30.0	167.0	8	2.20
CGH020	20	140.0	54.8	24.0	37.0	217.3	12.5	4.60
CGH022	22	162.2	68.0	28.0	44.0	255.2	15	8.20
CGH026	26	193.5	78.5	30.0	49.0	304.5	21.2	9.80
CGH032	32	228.0	95.0	38.0	57.0	360.5	31.5	19.40

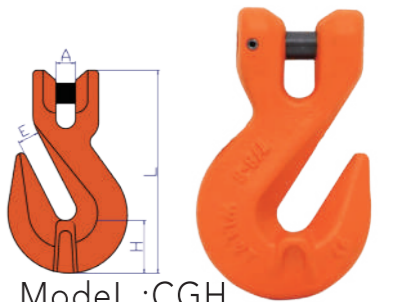

Model :CGH

Clevis Sling Hook With Latch

Stock No.	Size(mm)	Dimensions(mm)					W.L.L.(T)	Weight(LBS)	
		A	B	Ø	H	K			E
CSH006	6	9.0	35	27.0	20.5	74.0	21.0	1.12	0.17
CSH008	7/8	9.3	36.8	37.5	26.5	86.5	26.0	2	0.25
CSH010	10	12.4	46.6	44.5	33.5	104.0	30.0	3.15	0.65
CSH013	13	16.9	54.6	56.3	41.0	128.0	43.0	5.3	1.39
CSH016	16	21.5	70.5	63.5	49.5	157.0	47.0	8	2.20
CSH020	20	24	88.5	75.5	56.5	186.5	52.0	12.5	4.60
CSH022	22	28	90.0	98.0	63.0	205.0	68.0	15	8.20
CSH026	26	31.1	116.0	114.0	75.0	245.4	85.0	21.2	9.80
CSH032	32	35	150.0	140.0	88.0	317.0	106.0	31.5	19.40



Model :CSH



DIGITAL CRANE SCALE

- Use two 8.4V4.0AH lithium batteries, one inside and one spare.
- Metal panel, stainless steel button.
- Die-cast aluminum shell, beautiful and anti-corrosion.
- 5-bit (30mm) LED display, red and green words are optional.
- The battery voltage is automatically display edduring start up/shut down.



Model :MNCS



Model :MNCSL

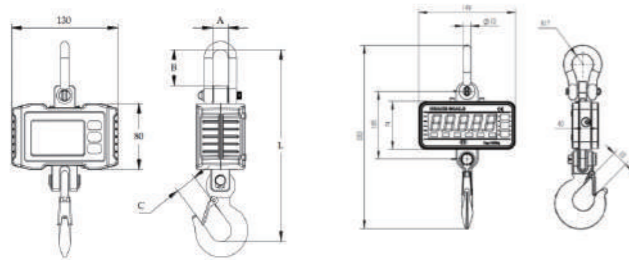

Technical Parameters

Model	Max.cap.		Min.cap.		Degree		Number n
	kg	lb	kg	lb	kg	lb	
MNCS-01	100	200	1	2	0.05	0.1	2000
MNCS-02	200	400	2	4	0.1	0.2	2000
MNCS-03	300	600	2	4	0.1	0.2	3000
MNCS-05	500	1000	4	10	0.2	0.5	2500
MNCSL-1	1000	2000	10	20	0.5	1	2000
MNCSL-01	100	200	1	2	0.05	1	2000
MNCSL-02	200	400	2	4	0.1	0.2	2000
MNCSL-03	300	600	2	4	0.1	0.2	3000
MNCSL-05	500	1000	4	10	0.2	0.5	2500
MNCSL-1	1000	2000	10	20	0.5	1	2000

- 30mm(1.2") LED /LCDdisplay(OCS-M).
- Hold function.
- Gross/Net weight display convertible.

Model	Max Cap(kg)	Min Division(kg)	Dimensions(mm)			N.W.(kg)
			A	B	C	
OCS-05	50	0.02	350	80	20	4
OCS-01	100	0.05	350	80	20	4
OCS-02	200	0.1	350	80	20	4
OCS-03	300	0.1	350	80	20	4
OCS-05	500	0.2	370	85	30	4.5
OCS-01	1000	0.5	370	85	30	4.5



Model :OCS

- Weight accumulation function.
- Auto shut function.
- Remote control calibration.

Model	Max Cap(kg)	Min Division(kg)	Dimensions(mm)			N.W.(kg)
			A	B	C	
OCS-1-B	1000	0.5	420	65	35	12
OCS-2-B	2000	1	600	80	45	14
OCS-3-B	3000	1	600	80	45	14
OCS-5-B	5000	2	730	100	55	24
OCS-10-B	10000	5	850	120	70	44
OCS-15-B	15000	5	900	140	70	60
OCS-20-B	20000	10	900	140	70	60



Model :OCS-B

- Easy to replace battery.
- AC/DC power adaptor: output DC9V/1.5A.
- 6V/10Ah rechargeable scaled leadacid battery.
- Remote distance: min.10m.

Model	Max Cap(kg)	Min Division(kg)	Dimensions(mm)			N.W.(kg)
			A	B	C	
OCS-1-H	1000	0.5	420	65	35	12
OCS-2-H	2000	1	600	80	45	14
OCS-3-H	3000	1	730	100	55	24
OCS-5-H	5000	2	850	120	70	44
OCS-10-H	10000	5	900	140	70	60
OCS-15-H	15000	10	900	140	70	60



Model :OCS-H

- Precision aluminum alloy case.
- High strength paint.
- 18mm LCD display.

Model	Max.cap.		Min.cap.		Degree		Number n
	kg	lb	kg	lb	kg	lb	
OCS-1-G	30	60	0.2	0.4	0.01	0.02	3000
OCS-2-G	60	120	0.4	0.8	0.02	0.05	3000
OCS-3-G	150	300	1	2	0.05	1	3000
OCS-5-G	300	600	2	4	0.1	0.2	3000



Model :OCS-G



LIFTING JACK

Manual Hydraulic Cylinder with Toe-lift

Widely used in mechanical equipment, bridge construction, railway track and other aspects of the installation and maintenance, transportation heavy loading and unloading, car tractor repair.



Model :HTL

STANDARD FLOOR JACK

- Large Steel Casters and swivel casters for easy maneuverability.
- Lightweight for easy mobility and transport.
- All welded steel frame construction with rust resistant finish for longer tool life.
- Meet ANSI/AS ME&CE/GS standards.



Model :HFJ

Model	Capacity (T)	Head Capacity (T)	Min.toc Height (mm)	Max.toc Height (mm)	Min.Head Height (mm)	Max.Head Height (mm)	Packing size (mm)	Net Weight (kg)
HTL025	5	2.5	16	130	235	362	215x160x260mm	10
HTL050	10	5	25	148	295	418	305x220x320mm	24
HTL100	20	10	32	173	330	471	325x275x355mm	38
HTL150	30	15	32	200	345	520	330x280x360mm	48
HTL250	50	25	40	160	390	520	395x300x420mm	80

Model	Lifting Wt (ton)	Min.H(mm)	Lifting.H.(mm)	Max H.(mm)	Net.WT(kg)	GR.WT.(Kg)	Quantity (pcs)	Package	Measurement (cm)	20'Container (pcs)
HFJ001	2	125	175	300	6.5	7.5	1	Blow case	45x22.5x14.5	2400
HFJ002	2	125	175	300	6.5	7	1	Color box	43x20x13.5	2600
HFJ003	2	135	200	335	7.5	8.5	1	Blow case	48x23.3x15.5	1900
HFJ003	2	135	200	335	7.5	8	1	Color box	45.5x20x14.5	2100
HFJ005	2	135	200	335	8.5	9.5	1	Blow case	48x23.3x15.5	1900
HFJ005	2	135	200	335	8.5	9	1	Color box	45.5x21x14.5	2100
HFJ007	2	135	215	350	9.5	11	1	Blow case	53x23.0x15.0	1500
HFJ008	2	135	215	350	9.5	10	1	Color box	50.5x21x15.0	1400
HFJ014	1.5	125	175	300	7	8	1	Blow case	45x22.5x14.5	2400
HFJ015	1.5	125	175	300	7	7.5	1	Color box	43x20x13.5	2600

Hydraulic Jack

- The load must be stable during lifting.
- Unit must be used on flat surfaces able on carry the load.



Model :HYJ

Hydraulic Bottle Jack Standard Type

High performance, low failure, long life.

Model	Capacity (T)	Min.H(mm)	Lifting.H.(mm)	Adjust H.(mm)	N.W.(Kg)	Qty/Ctn(pcs)
HBJ002	2	148	80	50	2.2	10
HBJ004	4	180	110	60	3	5
HBJ006	6	185	110	60	3.8	5
HBJ008	8	200	125	60	4.8	4
HBJ010	10	200	125	60	5.3	4
HBJ012	12	210	125	60	6.5	4
HBJ016	16	225	140	60	7.5	2
HBJ020	20	235	145	60	10	2
HBJ050	50	255	150	60	20	1
HBJ 050	50	230	120	60	19.5	1
HBJ100	100	335	180		68	1
HBJ200	200	370	200		138	1



Model :HBJ



DOUBLE-ACTING hydraulic cylinders series

- Double-acting, allowing for both push and pull forces.
- Baked enamel finish for increased corrosion resistance.
- Built-in safety valve prevents accidental overload.



HHYG cylinder is the best solution to precise controlled heavy loads.



Replacing adjustment rolls under a fly-over with RR cylinders, for controlled lifting and lowering.

SPECIFICATION

Model	Tonnage (T)	Stroke (mm)	Oil capacity (cm ³)	Closed height A(mm)	Extended Height B(mm)	Outside Dia. (mm)	Inside Dia. E(mm)	Piston Dia. F(mm)	G.W. (Kg)
PR-10250	10	250	491	390	630	70	45	36	10
PR-10300	10	300	589	430	730	70	45	36	11
PR-20250	20	250	707	390	640	80	60	45	13
PR-20300	20	300	848	440	740	80	60	45	15
PR-30200	30	200	884	364	564	95	75	65	17
PR-30300	30	300	1325	464	764	95	75	65	21
PR-50200	50	200	1418	374	574	120	95	70	29
PR-50300	50	300	2128	474	774	120	95	70	35
PR-100200	100	200	2863	389	589	175	135	90	60
PR-100300	100	300	4294	489	789	175	135	90	73
PR-20050	200	50	1418	217	267	228	190	135	83
PR-200150	200	150	4253	317	467	228	190	135	84
PR-200300	200	300	8508	467	767	228	190	135	146
PR-25050	250	50	1815	261	311	270	215	180	102
PR-250150	250	150	5448	361	511	270	215	180	135
PR-250300	250	300	10892	511	811	270	215	180	184
PR-30050	300	50	2262	280	330	285	240	200	133
PR-300150	300	150	6785	380	530	285	240	200	173
PR-300300	300	300	13572	530	830	285	240	200	231
PR-40050	400	50	2863	341	391	325	270	220	211
PR-400150	400	150	8588	441	591	325	270	220	262
PR-400300	400	300	17177	591	891	325	270	220	336
PR-50050	500	50	3653	376	426	372	305	250	309
PR-500150	500	150	10959	476	626	372	305	250	360
PR-500300	500	300	21918	626	926	372	305	250	460
PR-60050	600	50	4276	397	447	402	330	270	381
PR-600150	600	150	12829	497	647	402	330	270	458
PR-600300	600	300	25659	647	947	402	330	270	575
PR-80050	800	50	5973	438	488	472	390	320	583
PR-800150	800	150	17919	538	688	472	390	320	681
PR-800300	800	300	35838	688	988	472	390	320	850
PR-100050	1000	50	7261	493	543	650	450	360	830
PR-1000150	1000	150	21783	620	820	650	450	360	970
PR-1000300	1000	300	43566	720	1020	650	450	360	1177

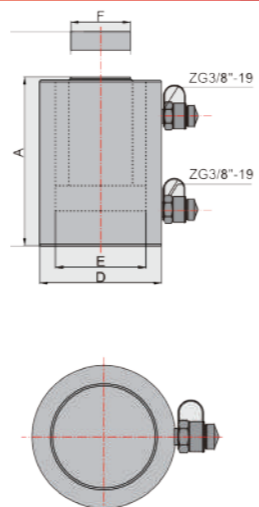

HYDRAULIC CYLINDERS

Lightweight, easy to carry.
 Baked enamel finish for increased corrosion resistance.
 All the raw material specially heat-treated and processed by imported CNC lathes.
 Import high quality seals to provide better protection to the cylinder, making the cylinder not easy to wear out.



- Hard underlay (avoid plunger break when it is overloading)
- Stopping ring (to protect the cylinder when the stroke get to top, absorb heaviness in the other side)
- Spring (provide the capability of quick flexing)
- Cylinder wall and principal axis (they can avoid eroding and less friction by chrome plate)
- O-ring (great sealing performance, long service life)
- Stopping ring (to protect the cylinder when the stroke get to top, absorb heaviness in the other side.)

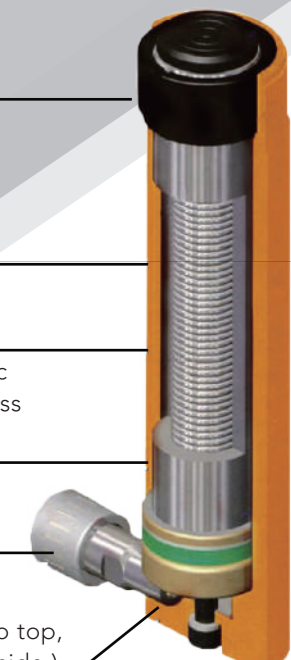

SPECIFICATION

Model	Tonnage (T)	Stroke (mm)	Oil capacity (cm ³)	Closed height A(mm)	Extended Height B(mm)	Outside Dia. (mm)	Inside Dia. E(mm)	Piston Dia. F(mm)	G.W. (Kg)
RSC-1050	10	50	85	120	170	60	45	38	3.1
RSC-10100	10	100	169	170	270	60	45	38	4.4
RSC-10150	10	150	254	220	370	60	45	38	5.7
RSC-2050	20	50	157	120	170	88	65	53	4
RSC-20100	20	100	311	170	270	88	65	53	5.3
RSC-20150	20	150	465	220	370	88	65	53	6.6
RSC-3050	30	50	237	120	170	107	75	68	7.9
RSC-30100	30	100	471	170	270	107	75	68	10.7
RSC-30150	30	150	705	220	370	107	75	68	13.5
RSC-5050	50	50	389	120	170	127	95	85	11.6
RSC-50100	50	100	768	170	270	127	95	85	14.9
RSC-50150	50	150	1147	220	370	127	95	85	18
RSC-10050	100	50	779	120	170	177	130	110	25.7
RSC-100100	100	100	1530	170	270	177	130	110	30.8
RSC-100150	100	150	2281	220	320	177	130	110	35.5
RSC-15050	150	50	1133	182	232	205	165	115	43
RSC-150100	150	100	2237	232	332	205	165	115	53
RSC-150150	150	150	3342	282	432	205	165	115	63
RSC-20050	200	50	1500	202	252	228	190	135	60
RSC-200100	200	100	2953	252	352	228	190	135	71
RSC-200150	200	150	4406	302	452	228	190	135	83
RSC-25050	250	50	1815	248	298	270	215	180	105
RSC-250150	250	150	5446	348	498	270	215	180	142
RSC-250300	250	300	10892	498	798	270	215	180	196
RSC-30050	300	50	2262	267	317	285	240	200	126
RSC-300150	300	150	6786	367	517	285	240	200	165
RSC-300300	300	300	13572	517	817	285	240	200	224
RSC-40050	400	50	2863	315	365	325	270	220	195
RSC-400150	400	150	8588	415	565	325	270	220	245
RSC-400300	400	300	17177	565	865	325	270	220	318
RSC-50050	500	50	3653	345	395	373	305	250	283
RSC-500150	500	150	10959	445	595	373	305	250	349
RSC-500300	500	300	21918	595	895	373	305	250	451

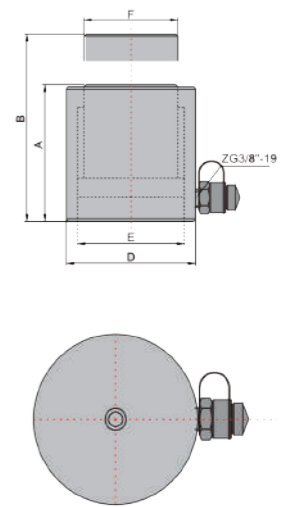



MULTI-STAGE HYDRAULIC CYLINDERS

- Lightweight, low profile design for use in confined spaces.
- Baked enamel finish for increased corrosion resistance.
- Plunger wiper reduces contamination, Extending Cylinder life.
- It is easy to carry, there are two holes on the surface of the oil vat for stability.
- Match pump HHB-700, HHB-800, HHB-600A.



SPECIFICATION

Model	Tonnage (T)	Stroke (mm)	Oil capacity (cm ³)	Closed height A(mm)	Extended Height B(mm)	Outside Dia. (mm)	G.W. (Kg)
FPY-10	10	25	30	49	74	83x60	1.6
FPY-20	20	26	51	52	80	99x76	2.7
FPY-30	30	53	123	63	118	115x95	4.5
FPY-50	50	64	188	69	135	138x115	7.9
FPY-100	100	69	418	86	162	185x160	16.9

LOW HEIGHT HYDRAULIC CYLINDERS

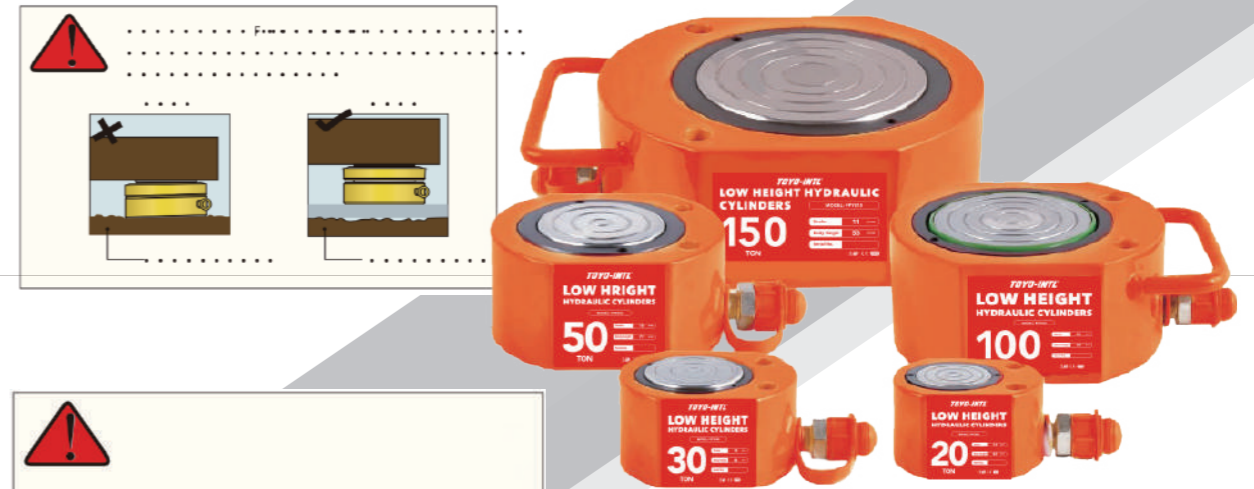

All FPY series cylinders require a solid lifting surface for correct support. Using cylinders on surfaces such as sand, mud or dirt may result in cylinder damage!

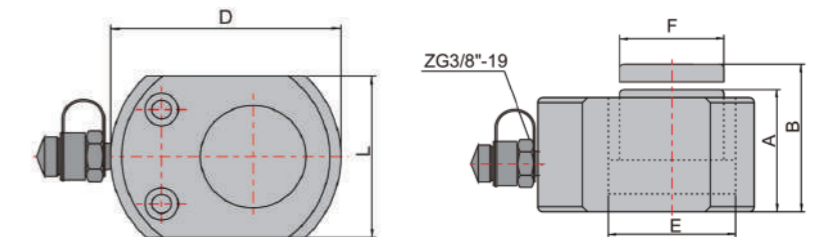
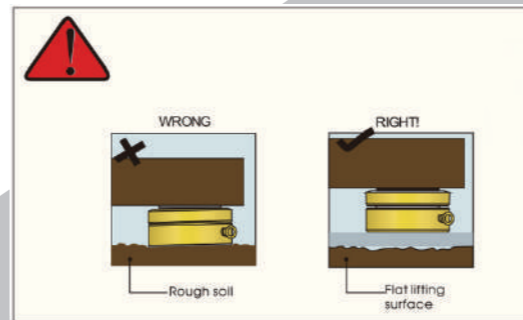

SPECIFICATION

Model	Tonnage (T)	Stroke (mm)	Oil capacity (cm ³)	Closed height A(mm)	Extended Height B(mm)	Outside Dia. (mm)	Inside Dia. E(mm)	Piston Dia. F(mm)	G.W. (Kg)
FPY-101	10	10	16	47	58	83x60	45	38	1.6
FPY-201	20	11	34	52	63	99x76	60	50	2.7
FPY-301	30	12	55	62	75	115x95	75	63	4.6
FPY-501	50	16	101	69	85	138x115	95	85	7.8
FPY-1001	100	16	200	86	102	188x160	130	110	16.8
FPY-1501	150	16	342	100	116	215x190	165	115	27
FPY-2001	200	20	567	96	116	255x240	195	125	42



RATCHET PULLER

- Ratchet and other core components use high-quality alloy steel.
- The hook is made of 35 crmo material.
- Forward/reverse load holding mechanism 360° Handle movement
- Fast advance mechanism.
- High quality galvanized steel wire rope.

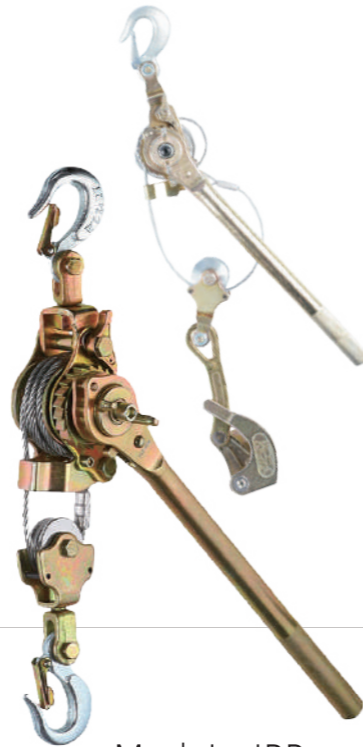
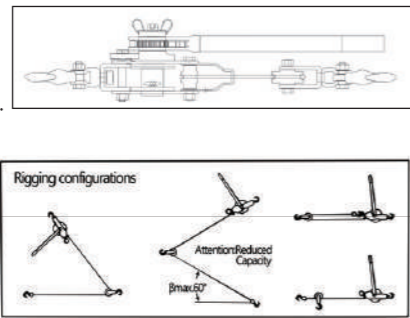

Model :JRP

HAND WINCH

- The cost-effective solution for a wide variety of applications, Brake Hand Winches can be used to pull or lift loads.
- Positive action brake can hold the load in any position.

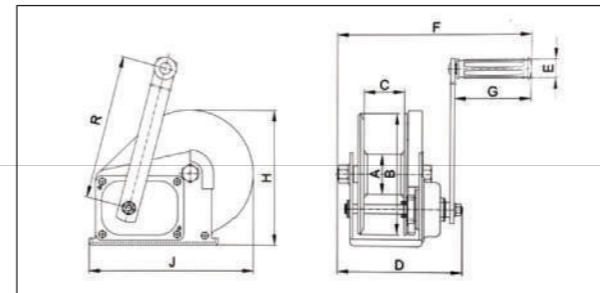

Model :BHW

Model	JRP-1000	JRP-1500	JRP-2000	JRP-3000
Rated capacity	1.0	1.5	2.0	3.0
Wire rope diameter(mm) * length(mm)	5*2300	6*2300	6*2300	8*2300
Length of the after tightening	580	680	680	780
Net weight	3.30	4.35	4.70	6.5

WIRE GRIP

- Product is forged of alloy steel with heat treatment.
- The rack has strong anti-tension with high occlusion strength.
- The clamping jaw are made of 20crmnti carburizing steel, doubling the service life.

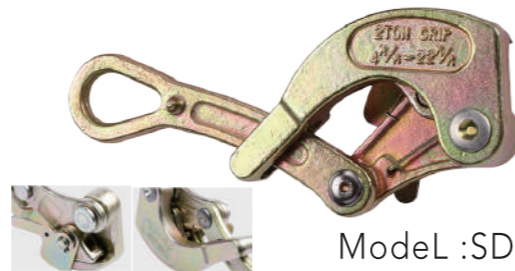

Model :SD

Model	SD-0.5	SD-1	SD-2	JX-3
Rated capacity	0.5	1	2	3
Wire diameter Recommend mm	1-10	2.5-16	4-22	16-32
Dimensions mm	A	55	71	91
	B	131	189	248
	C	16	25	25
	D	16	37	42
Net weight	0.45	0.75	1.5	2.5

Ideal for use in confined locations, the ratchet handle permits reciprocating handle movement in both directions for hoisting and lowering loads.

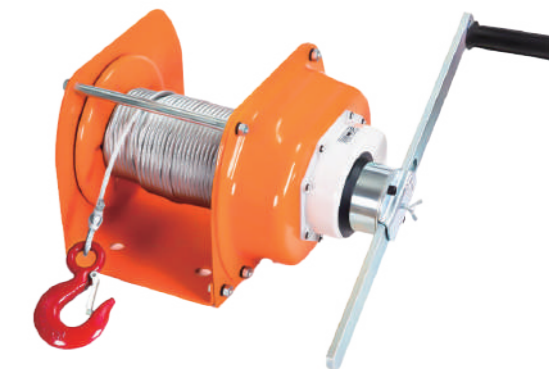
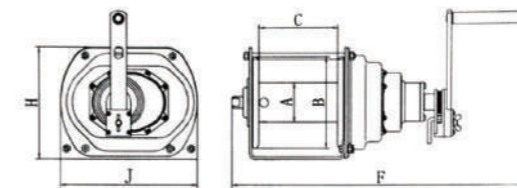

Model :JHW

Model	Safe Working Load(t)	Test load (kN)	Adopted wire rope dia.*length(m)	Transmission ratio	The max length of link-pole action(mm)	Min.force of hand turn (N)	Dimensions(mm)								Net weight (kg)	
							A	B	C	D	E	F	H	I		J
0.5t	0.5	6.125	Φ6.3*40	4.33:1	350	120	Φ60	Φ140	150	100	Φ15	403	182	130	245	14.4
1t	1	12.25	Φ8*40	12.19:1	350	120	Φ76	Φ175	154	110	Φ18	443	214	170	286	19.7
2t	2	24.5	Φ9*40	22.68:1	350	130	Φ90	Φ190	195	155	Φ18	490	230	170	300	25.1
3t	3	36.75	Φ12.5*40	29.16:1	350	180	Φ100	Φ230	205	155	Φ18	549	296	170	365	44.3



CARGO TROLLEY

Turnable with bearings
SPECIFICATIONS

Item No.	Capacity(t)	N.W.(kg)
RSA06	6	13.95
RSA08	8	20.8
RSA12	12	27.1
RSA18	18	42.45



Model :RSA

ROLLER SKATES

Mode	RS-W-6	RS-W-8	RS-W-12	RS-W-15	RS-W-24	RS-W-30
Maximum load(T)	6	8	12	15	24	30
Normal load(T)	4	6	8	12	18	24
LxWxH(mm)	80x70	80x70	80x70	80x 70(Double)	80x70(Double)	100x70(Double)
Net Weight(kg)	14	20	32	36	52	86
Number of wheels	4	6	8	6	8	8
The material of wheel	PU wheel	Steel wheel				

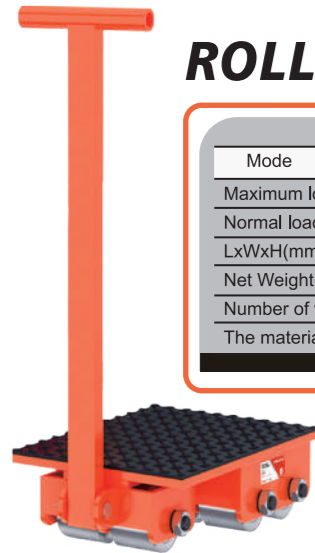

Model :RS-W

- Shifting skates can be used wherever heavy objects have to be moved. The load can be lifted using either the roller crowbar or a jack, allowing the skates to be easily positioned.
- The large diameter sealed nylon roller ensure ease of movement and spread the load, protecting high quality floors from damage caused by highpoint loads and oil/grease contamination.



Model :RS-C

Mode	RS-C-2	RS-C-4	RS-C-6	RS-C-10	RS-C-15
Maximum load(T)	3	5	8	12	18
Normal load(T)	2	4	6	10	15
LxWxH(mm)	500x480x110	630x550x110	630x550x110	650x560x110	720x620x110
Net Weight(kg)	20.5	32.5	45	67	88
Number of wheels	3	5	3	4	5
The material of wheel	PU wheel / Steel wheel				

HYDRAULIC HAND PALLET TRUCK

AC SERIES

The Hand Pallet Truck is the ideal "storage aid" and "handling partner" for all manual transport tasks over short distances, excellently suitable for use on lorries, in small warehouses and markets ect.



Model :AC

Model	AC 2.0	AC 2.5	AC 3.0	AC 5.0
Capacity(kg)	2000	2500	3000	5000
Min.fork height(mm)	85/75	85/75	85/75	85/75
Max.fork height(mm)	195/185	195/185	195/185	195/185
Lifting height(mm)	110	110	110	110
Fork length(mm)	1150/1220	1150/1220	1150/1220	1150/1220
Single fork width(mm)	160	160	160	160
Width overall forks(mm)	550/685	550/685	550/685	550/685
Fork wheel-single(mm)	80X93/74X93	80X93/74X93	80X93/74X93	80X93/74X93
Fork wheel-tandem(mm)	80X70	80X70	80X70	80X70
Steering wheel(mm)	180X50	180X50	180X50	180X50
Self weight(kg)	73-92	73-92	73-92	73-92
Qty/20 feet container (pcs)	180/144	180/144	180/144	180/144

CW SERIES

Hand Pallet Truck with scale is an excellent economic solution for all weighing requirements in a busy warehouse environments, which allows you to weigh cargo where you want and when you want.



Model	CW
Capacity(kg)	1500/2000/2500/3000
Total lift height(mm)	195
Lowered fork height(mm)	85
Fork length(mm)	1150/1220
Width overall forks(mm)	550/685
Steering wheel(mm)	φ 180x50
Fork wheel(mm)	φ 80x70
Truck weight(kg)	120-130



Model :CW



BOW SHACKLE

US TYPE SCREW PIN ANCHOR BOW SHACKLE G209 S209

(Hot ash zinc plating craft—More beautiful, more corrosion resistance; 6:1 SAFETY FACTOR)

Nominal Size (in.)	Working Load Limit(t)	Weight Each (lbs.)	Dimensions(in.)												Tolerance +/-	
			A	B	C	D	E	F	G	H	L	M	P	C	A	
3/16	1/3	0.06	0.38	0.25	0.88	0.19	0.60	0.56	0.98	1.47	0.16	1.12	0.19	0.06	0.06	
1/4	1/2	0.10	0.47	0.31	1.13	0.25	0.78	0.61	1.28	1.84	0.19	1.38	0.26	0.06	0.06	
5/16	3/4	0.19	0.53	0.38	1.22	0.31	0.84	0.75	1.47	2.09	0.22	1.66	0.31	0.06	0.06	
3/8	1	0.31	0.66	0.44	1.44	0.38	1.03	0.91	1.78	2.49	0.25	2.03	0.38	0.13	0.06	
7/16	1-1/2	0.38	0.75	0.50	1.69	0.44	1.16	1.06	2.03	2.91	0.31	2.38	0.44	0.13	0.06	
1/2	2	0.72	0.81	0.63	1.88	0.50	1.31	1.19	2.31	3.28	0.38	2.69	0.50	0.13	0.06	
5/8	3-1/4	1.37	1.06	0.75	2.38	0.63	1.69	1.50	2.94	4.19	0.44	3.34	0.69	0.13	0.06	
3/4	4-3/4	2.35	1.25	0.88	2.81	0.75	2.00	1.81	3.50	4.97	0.50	3.97	0.81	0.25	0.06	
7/8	6-1/2	3.62	1.44	1.00	3.31	0.88	2.28	2.09	4.03	5.83	0.50	4.50	0.97	0.25	0.06	
1	8-1/2	5.03	1.69	1.13	3.75	1.00	2.69	2.38	4.69	6.56	0.56	5.07	1.06	0.25	0.06	
1-1/8	9-1/2	7.41	1.81	1.25	4.25	1.16	2.91	2.69	5.16	7.47	0.63	5.59	1.25	0.25	0.06	
1-1/4	12	9.50	2.03	1.38	4.69	1.29	3.25	3.00	5.75	8.25	0.69	6.16	1.38	0.25	0.06	
1-3/8	13-1/2	13.53	2.25	1.50	5.25	1.42	3.63	3.31	6.38	9.16	0.75	6.84	1.50	0.25	0.13	
1-1/2	17	17.20	2.38	1.63	5.75	1.54	3.88	3.63	6.88	10.00	0.81	7.35	1.62	0.25	0.13	
1-3/4	25	27.78	2.88	2.00	7.00	1.84	5.00	4.19	8.86	12.34	1.00	9.08	2.25	0.25	0.13	
2	35	45.00	3.25	2.25	7.75	2.08	5.75	4.81	9.97	13.68	1.22	10.34	2.40	0.25	0.13	
2-1/2	55	85.75	4.13	2.75	10.50	2.71	7.25	5.69	12.87	17.84	1.38	13.00	3.13	0.25	0.25	



Model :G209

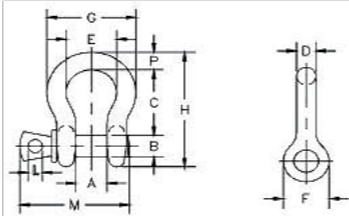

D SHACKLE

US TYPE SCREW PIN ANCHOR D SHACKLE G210 S210

(Hot ash zinc plating craft—More beautiful, more corrosion resistance; 6:1 SAFETY FACTOR)

Nominal Size (in.)	Working Load Limit(t)	Weight Each (lbs.)	Dimensions(in.)											Tolerance +/-	
			A	B	C	D	E	F	G	K	L	M	G	A	
1/4	1/2	0.11	0.47	0.31	0.25	0.25	0.97	0.62	0.97	1.59	0.19	1.43	0.06	0.06	
5/16	3/4	0.17	0.53	0.38	0.31	0.31	1.15	0.75	1.07	1.91	0.22	1.71	0.06	0.06	
3/8	1	0.28	0.66	0.44	0.38	0.38	1.42	0.92	1.28	2.31	0.25	2.02	0.13	0.06	
7/16	1-1/2	0.43	0.75	0.50	0.44	0.44	1.63	1.06	1.48	2.67	0.31	2.37	0.13	0.06	
1/2	2	0.59	0.81	0.63	0.50	0.50	1.81	1.18	1.66	3.03	0.38	2.69	0.13	0.06	
5/8	3-1/4	1.25	1.06	0.75	0.63	0.63	2.32	1.50	2.04	3.76	0.44	3.34	0.13	0.06	
3/4	4-3/4	2.63	1.25	0.88	0.81	0.75	2.75	1.81	2.40	4.53	0.50	3.97	0.25	0.06	
7/8	6-1/2	3.16	1.44	1.00	0.97	0.88	3.20	2.10	2.86	5.33	0.50	4.50	0.25	0.06	
1	8-1/2	4.75	1.69	1.13	1.00	1.00	3.69	2.38	3.24	5.94	0.56	5.13	0.25	0.06	
1-1/8	9-1/2	6.75	1.81	1.25	1.25	1.13	4.07	2.69	3.61	6.78	0.63	5.71	0.25	0.06	
1-1/4	12	9.06	2.03	1.38	1.38	1.25	4.53	3.00	3.97	7.50	0.69	6.25	0.25	0.13	
1-3/8	13-1/2	11.63	2.25	1.50	1.50	1.38	5.01	3.31	4.43	8.28	0.75	6.83	0.25	0.13	
1-1/2	17	15.95	2.38	1.63	1.62	1.50	5.38	3.62	4.84	9.05	0.81	7.33	0.25	0.13	
1-3/4	25	26.75	2.88	2.00	2.12	1.75	6.38	4.19	5.78	10.97	1.00	9.06	0.25	0.13	
2	35	42.31	3.25	2.25	2.36	2.10	7.25	5.00	6.77	12.74	1.13	10.35	0.25	0.13	
2-1/2	55	71.75	4.12	2.75	2.63	2.63	9.38	5.68	8.07	14.85	1.38	13.00	0.25	0.25	



Model :G210

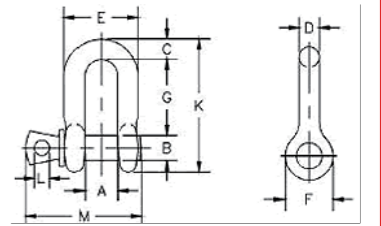

US BOLT TYPE ANCHOR BOW SHACKLE G2130 S2130

(Hot ash zinc plating craft—More beautiful, more corrosion resistance; 6:1 SAFETY FACTOR)

Nominal Size (in.)	Working Load Limit (t)	Weight Each (lbs.)	Dimensions(in.)												Tolerance +/-	
			A	B	C	D	E	F	H	I	N	C	A			
3/16	1/3	0.06	0.38	0.25	0.88	0.19	0.60	0.56	1.47	0.98	0.19	0.06	0.06			
1/4	1/2	0.11	0.47	0.31	1.13	0.25	0.78	0.61	1.84	1.28	0.25	0.06	0.06			
5/16	3/4	0.22	0.53	0.38	1.22	0.31	0.84	0.75	2.09	1.47	0.31	0.06	0.06			
3/8	1	0.33	0.66	0.44	1.44	0.38	1.03	0.91	2.49	1.78	0.38	0.13	0.06			
7/16	1-1/2	0.49	0.75	0.50	1.69	0.44	1.16	1.06	2.91	2.03	0.44	0.13	0.06			
1/2	2	0.79	0.81	0.64	1.88	0.50	1.31	1.19	3.28	2.31	0.50	0.13	0.06			
5/8	3-1/4	1.68	1.06	0.77	2.38	0.63	1.69	1.50	4.19	2.94	0.69	0.13	0.06			
3/4	4-3/4	2.72	1.25	0.89	2.81	0.75	2.00	1.81	4.97	3.50	0.81	0.25	0.06			
7/8	6-1/2	3.95	1.44	1.02	3.31	0.88	2.28	2.09	5.83	4.03	0.97	0.25	0.06			
1	8-1/2	5.66	1.69	1.15	3.75	1.00	2.69	2.38	6.56	4.69	1.06	0.25	0.06			
1-1/8	9-1/2	8.27	1.81	1.25	4.25	1.13	2.91	2.69	7.47	5.16	1.25	0.25	0.06			
1-1/4	12	11.71	2.03	1.40	4.69	1.29	3.25	3.00	8.25	5.75	1.38	0.25	0.06			
1-3/8	13-1/2	15.83	2.25	1.53	5.25	1.42	3.63	3.31	9.16	6.38	1.50	0.25	0.13			
1-1/2	17	20.80	2.38	1.66	5.75	1.53	3.88	3.63	10.00	6.88	1.62	0.25	0.13			
1-3/4	25	33.91	2.88	2.04	7.00	1.84	5.00	4.19	12.34	8.80	2.25	0.25	0.13			
2	35	52.25	3.25	2.30	7.75	2.08	5.75	4.81	13.68	10.15	2.40	0.25	0.13			
2-1/2	55	98.25	4.13	2.80	10.50	2.71	7.25	5.69	17.90	12.75	3.13	0.25	0.25			
3	85	154.00	5.00	3.30	13.00	3.12	7.88	6.50	21.50	14.62	3.62	0.25	0.25			
3-1/2	120	265.00	5.25	3.76	14.63	3.62	9.00	8.00	24.88	17.02	4.38	0.25	0.25			
4	150	338.00	5.50	4.26	14.50	4.00	10.00	9.00	25.68	18.00	4.56	0.25	0.25			



Model :G2130

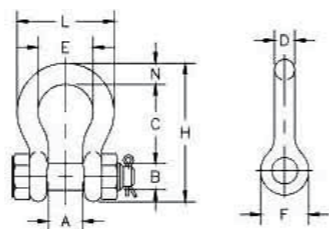

US BOLT TYPE ANCHOR D SHACKLE G2150 S2150

(Hot ash zinc plating craft—More beautiful, more corrosion resistance; 6:1 SAFETY FACTOR)

Nominal Size (in.)	Working Load Limit (t)	Weight Each (lbs.)	Dimensions(in.)											Tolerance +/-	
			A	B	D	F	G	K	M	P	R	G	A		
1/4	1/2	0.13	0.47	0.31	0.25	0.62	0.91	1.59	0.97	1.56	0.25	0.06	0.06		
5/16	3/4	0.23	0.53	0.38	0.31	0.75	1.07	1.91	1.15	1.82	0.31	0.06	0.06		
3/8	1	0.33	0.66	0.44	0.38	0.92	1.28	2.31	1.42	2.17	0.38	0.13	0.06		
7/16	1-1/2	0.49	0.75	0.50	0.44	1.06	1.48	2.67	1.63	2.51	0.44	0.13	0.06		
1/2	2	0.75	0.81	0.64	0.50	1.18	1.66	3.03	1.81	2.80	0.50	0.13	0.06		
5/8	3-1/4	1.47	1.06	0.77	0.63	1.50	2.04	3.76	2.32	3.56	0.63	0.13	0.06		
3/4	4-3/4	2.52	1.25	0.89	0.75	1.81	2.40	4.53	2.75	4.15	0.81	0.25	0.06		
7/8	6-1/2	3.85	1.44	1.02	0.88	2.10	2.86	5.33	3.20	4.82	0.97	0.25	0.06		
1	8-1/2	5.55	1.69	1.15	1.00	2.38	3.24	5.94	3.69	5.39	1.00	0.25	0.06		
1-1/8	9-1/2	7.60	1.81	1.25	1.13	2.68	3.61	6.78	4.07	5.90	1.25	0.25	0.06		
1-1/4	12	10.81	2.03	1.40	1.25	3.00	3.97	7.50	4.53	6.69	1.38	0.25	0.06		
1-3/8	13-1/2	13.75	2.25	1.53	1.38	3.31	4.43	8.28	5.01	7.21	1.50	0.25	0.13		
1-1/2	17	18.50	2.38	1.66	1.50	3.62	4.87	9.05	5.38	7.73	1.62	0.25	0.13		
1-3/4	25	31.40	2.88	2.04	1.75	4.19	5.82	10.97	6.38	9.33	2.12	0.25	0.13		
2	35	46.75	3.25	2.30	2.10	5.00	6.82	12.74	7.25	10.41	2.36	0.25	0.13		
2-1/2	55	85.00	4.12	2.80	2.63	5.68	8.07	14.85	9.38	13.58	2.63	0.25	0.25		
3	85	124.25	5.00	3.25	3.00	6.50	8.56	16.87	11.00	15.13	3.50	0.25	0.25		



Model :G2150

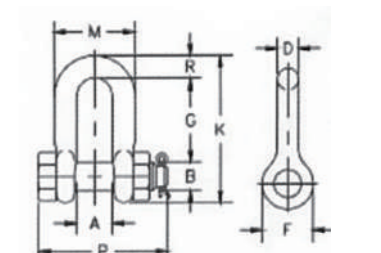

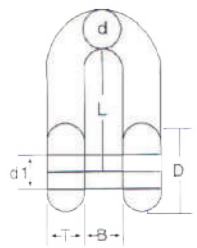

Model:JIS-D

Nominal Size		Dimensions(mm)					SWL	
mm	in	B	D	L	d1	Ton	Kg	
4.8	3/16	10	10	18.5	5.0	0.09	0.014	
6	1/4	12	11	25	6.5	0.15	0.028	
8	5/16	14	15	31	8.5	0.25	0.049	
9	3/8	18	17	36	10	0.4	0.049	
12	1/2	24	23	46	13	0.6	0.18	
16	5/8	30	32	59	17	0.8	0.42	
19	1/3	36	37	74	20	1.0	0.72	
22	7/8	43	43	86	23	1.5	1.18	
25	1	47	50	95	27	2.0	1.8	
28	1-1/8	55	56	110	30	2.5	2.5	
32	1-1/4	64	64	130	34	3.2	3.7	
38	1-1/2	76	76	145	40	4.2	6.1	
44	1-3/4	80	90	160	47	6.5	-	
50	2	100	100	185	53	8	-	
65	2-1/2	110	130	240	68	15	-	
75	2	120	150	300	78	20	-	

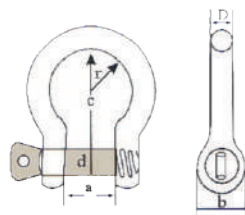

Model:JIS-B

SWL(Kg)	Dimensions(mm)						Approx 100pcs/WT(Kg)
	D	d	a	c	r	b	
80	5	5	10	19	8	11	1.9
100	6	6	13	25	10	14	34
200	8	8	16	32	12	18	7
320	10	10	19	38	16	20	13
520	12	12	25	51	19	26	26
800	16	16	32	64	28	33	50
1100	20	20	38	76	33	40	80
1500	22	22	44	89	37	50	130
2100	25	25	51	100	40	57	200
3000	28	28	57	115	47	68	310
3500	32	32	64	127	52	73	430
5000	38	38	76	152	63	85	700
7000	45	45	90	180	75	96	1250
8000	50	50	102	200	78	108	1750

D RING SHACKLES

- Material: Heavy Duty Steel
- Working Load Limit: 5 Ton (11023 Lbs Capacity)
Breaking Load Limit: 19 Ton (41850 Lbs Capacity)
Color: Black, Red
- Made of Drop-Forged Steel and use an electroplated coating that does not rust, does not fade and is extremely durable. Keep your safety at all times!
- Comes with washers for reducing the noises. Just unscrew the pins, attach the shackles to your car, and re-screw. Let it be a good helper for solving your problem immediately.



Model :CAS

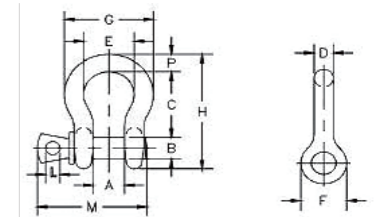

Model :CAS-1



Model :CAS-2

Nominal size(in.)	Working Load Limit(t)	Weight Each (lbs.)	Tolerance												
			A	B	C	D	E	F	G	H	L	M	P	C	A
3/4	4-3/4	2.35	1.25	0.88	2.81	0.75	2.00	1.81	3.50	4.97	0.50	3.97	0.81	0.25	0.06



TURNBUCKLE

Turnbuckles to U.S.Federal Specification(FF-T-791b)—Hot dip galvanizing craft

Size (Diameter x Take-Up)	Average Overall Length with Ends in Closed Position	Approx.Weight Each(lbs)					Working Load Limit(lbs)	
		Eyes and / or Hooks	Jaw & Eye	Jaw & Jaw	Stub End	Bodies Only	Hood & Hook Hood & Eye	Eye & Eye; Jaw & Eye Jaw & Jaw; Stub End
1/4"x4"	8-14	0.30	0.30	0.40	0.29	0.17	0.400	0.500
5/16"x4-1/2"	9-9 1/8	0.50	0.35	0.58	0.46	0.25	0.700	0.800
3/8"x6"	11-7 1/8	0.75	0.62	0.93	0.75	0.30	1.000	1.200
1/2"x6"	13-5 1/8	1.50	1.62	1.88	1.38	0.55	1.500	2.200
1/2"x8"	16-5 1/8	1.75	1.82	1.85	1.89	0.74	1.500	2.200
1/2"x12"	19-5 1/8	2.18	2.19	2.20	2.0	0.83	1.500	2.200
5/8"x6"	15-1/2	2.63	2.59	2.82	2.15	0.91	2.250	3.500
5/8"x8"	18-1/2	3.00	3.01	3.25	2.70	1.20	2.250	3.500
5/8"x12"	21-1/2	3.25	3.50	3.75	3.22	1.50	2.250	3.500
3/4"x6"	17	3.75	4.25	4.68	3.25	1.30	3.000	5.200
3/4"x8"	20	4.50	5.00	5.38	4.00	1.70	3.000	5.200
3/4"x12"	23	5.75	5.75	6.12	4.65	2.12	3.000	5.200
3/4"x18"	29	7.00	7.25	7.25	6.12	2.93	3.000	5.200
7/8"x6"	18	-	-	-	4.75	2.00	-	7.200
7/8"x12"	24-5/8	8.38	8.88	9.38	6.62	3.00	4.000	7.200
7/8"x18"	30-5/8	10.29	10.60	11.44	8.75	4.12	4.000	7.200
1"x6"	20-5/8	-	-	-	6.41	2.50	-	10.000
1"x12"	26-5/8	11.25	12.00	12.88	8.80	3.88	5.000	10.000
1"x18"	32-5/8	14.00	14.75	16.10	11.70	5.50	5.000	10.000
1"x24"	38-5/8	17.00	17.75	18.60	14.30	7.00	5.000	10.000
1-1/4"x6"	20	-	-	-	10.40	4.00	-	15.200
1-1/4"x12"	29-7/8	19.00	21.20	23.60	14.20	5.93	-	15.200
1-1/4"x18"	35-7/8	24.10	26.00	26.60	18.00	8.00	-	15.200
1-1/4"x24"	41-7/8	28.10	28.70	31.20	21.80	10.00	-	15.200
1-1/2"x6"	22-7/8	-	-	-	15.40	5.80	-	21.400
1-1/2"x12"	32-3/8	27.00	31.10	35.50	20.50	8.40	-	21.400
1-1/2"x18"	38-3/8	31.20	36.40	40.70	26.20	11.50	-	21.400
1-1/2"x24"	44-3/8	38.20	44.20	47.60	31.40	14.10	-	21.400
1-3/4"x6"	-	-	-	-	22.70	8.75	-	28.000
1-3/4"x18"	41-3/4	45.00	48.80	52.40	-	-	-	28.000
1-3/4"x24"	47-3/4	58.00	60.00	64.00	43.90	19.50	-	28.000
2"x6"	-	-	-	-	31.50	12.50	-	37.000
2"x24"	51-3/4	90.00	102.00	115.00	60.30	27.50	-	37.000
2-1/2"x6"	-	-	-	-	60.80	27.00	-	60.000
2-1/2"x24"	51-1/2	183.00	180.00	200.00	110.00	54.00	-	60.000
2-3/4"x24"	61-1/2	180.00	214.00	248.00	-	54.00	-	75.000

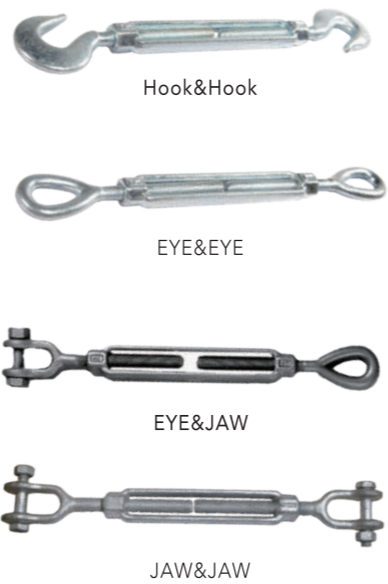

TURNBUCKLES Frame Japan Type(Forged Steel) — JIS (Electrogalvanizing craft)

① ⑥ Sides and Weights(Approx)

Nominal Size(D)	① Body Only				② Eye and Eye			③ Hook and Eye		④ Hook and Hook			⑥ With Stubs						
	A	B	C	T.L	F	T.L	W/Pcs	T.L	W/Pcs	E	T.L	W/Pcs	H	G	W/Pcs				
6	1/4	100	4	78	11	1	0.08	10	0.1	0.116	0.04	0.114	9	0.04	0.112	80	50	5.3	0.112
8	5/16	125	5	100	12.5	1.2	0.15	12	0.2	0.22	0.08	0.218	9	0.08	0.215	100	63	6.9	0.22
9	3/8	150	6	120	12.5	1.5	0.17	16	0.5	0.295	0.15	0.293	11	0.15	0.29	130	75	8.3	0.273
12	1/2	200	8	164	18	2	0.29	20	2	0.6	0.35	0.585	16	0.35	0.57	150	100	11.2	0.51
16	5/8	250	10	202	21.5	3	0.52	22	3	1.07	0.7	1.05	19	0.7	1.03	180	125	14.2	0.95
19	3/4	300	12	250	25	4	0.85	28	4	1.79	1.0	1.78	20	1.0	1.77	220	150	17.2	1.62
22	7/8	325	13	269	28	5	1.17	33	5	2.55	1.5	2.58	21	1.5	2.6	250	165	20.3	2.34
25	1	350	14	285	32.5	6	1.69	35	6	3.8	2.0	3.77	26	2.0	3.73	270	175	23.3	3.27
32	1-1/4	400	16	310	45	8	3.51	36x70	10	7.6	3.0	7.52	34	3.0	7.44	300	200	29	6.52

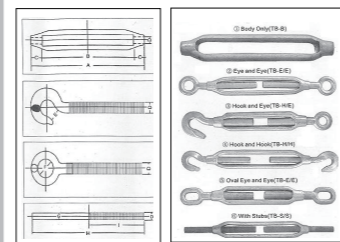

TURNBUCKLES COMMERCIAL TYPE (MALLEABLE IRON)

TURNBUCKLES COMMERCIAL TYPE(MALLEABLE)



WLL(Kg)	Specification	B	C	D	E	F	L	Weight(kg)
100	6x100mm	145	215	12	10	6	100	0.06
200	8x125mm	185	280	14	12	8	125	0.125
300	10x150mm	210	325	16	14	9	150	0.250
500	12x200mm	275	430	19	18	11	200	0.480
1000	16x250mm	345	540	23	24	14	250	0.980
1500	20x300mm	435	670	28	26	18	300	1.650
2200	22x330mm	480	740	34	32	20	330	2.350
3000	24x350mm	555	830	36	36	21	350	2.750

TURNBUCKLES WITH HOOK AND EYE
DIN 1480



Size (mm/in.)	Permissible Load		Weight (Kg/100p -cs)	Dimensions(mm)						
	Kg	N		l1	m	l2	b	d1	da	i
M6	230	2250	7.8	110	10	60	53	10	20	4.5
M8	418	4100	14.8	110	14	60	55	12	26	6.5
M10	663	6500	29.4	125	20	65	60	14	30.5	8
M12	948	9300	36.3	125	21	75	70	18	37.5	10
M16	1804	17700	91	170	27	100	90	22	48	13
M20	2752	27000	156	200	34	115	100	25	51	20
M24	3996	39200	325	255	39	140	130	28	66	27
M30	6371	62500	415	255	45	145	130	35	83	31
1-1/4"	6585	64600	595	295	55	160	150	36.5	88	33
M36	9276	91000	745	295	55	160	150	44	104	40
1-1/2"	9572	93900	1076	330	63	185	170	42	104	39



STAINLESS STEEL, SHACKLE, TURNBUCKLE, CLIP AISI 316 & AISI 304 RIGGING SCREWS

BOW SHACKLE

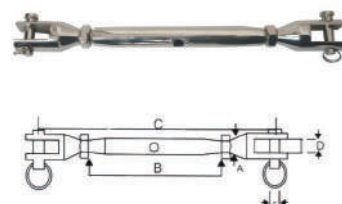

Code No.	A (mm)	B (mm)	C (mm)	D (mm)	E (mm)	WLL (T)	WT (Kg)
HL0251-0004	4	65	120	4	4	0.15	0.07
HL0251-0005	5	70	130	5	5	0.25	0.08
HL0251-0006	6	80	145	6	5	0.35	0.08
HL0251-0008	8	90	175	8	6	0.70	0.15
HL0251-0010	10	100	200	10	8	1.00	0.23
HL0251-0012	12	140	280	12	8	1.50	0.45
HL0251-0014	14	150	290	14	10	1.60	0.50
HL0251-0016	16	170	340	16	12	2.30	1.08
HL0251-0020	20	230	470	20	14	3.00	2.35

Code No.	A (mm)	B (mm)	C (mm)	D (mm)	WLL (T)	WT (Kg)
HL0107-0004	4	4	8	14	0.09	0.013
HL0107-0005	5	5	10	18	0.10	0.015
HL0107-0006	6	6	13	21	0.15	0.027
HL0107-0008	8	8	16	28	0.25	0.061
HL0107-0010	10	10	19	35	0.50	0.107
HL0107-0012	12	12	25	42	0.60	0.21
HL0107-0016	16	16	32	56	1.10	0.46
HL0107-0020	20	20	38	70	1.60	0.90
HL0107-0022	22	22	44	77	2.50	1.26
HL0107-0025	25	25	51	88	3.00	1.78
HL0107-0028	28	28	57	98	3.50	2.65
HL0107-0032	32	32	65	112	4.50	3.90

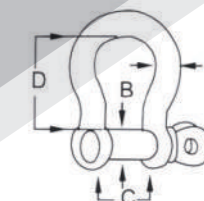

WIRE ROPE CLIP DIN741 TYPE

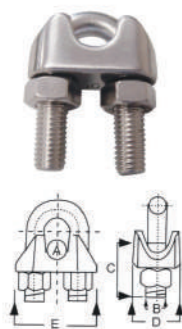

Code No.	A (mm)	B (mm)	C (mm)	D (mm)	E (mm)	WT (Kg)
HL0301-0003	3	4	12	10	21	0.014
HL0301-0005	5	5	13	11	23	0.015
HL0301-0006	6	5	15	12	26	0.021
HL0301-0008	8	6	19	14	30	0.041
HL0301-0010	10	8	22	18	34	0.068
HL0301-0011	11	8	22	19	36	0.072
HL0301-0013	13	10	30	23	42	0.130
HL0301-0014	14	10	30	23	44	0.135
HL0301-0016	16	12	33	26	50	0.210
HL0301-0019	19	12	38	29	54	0.280
HL0301-0022	22	14	44	33	61	0.400
HL0301-0025	25	14	45	35	65	0.440

D SHACKLE

Code No.	A (mm)	B (mm)	C (mm)	D (mm)	WLL (T)	WT (Kg)
HL0108-0004	4	4	8	14	0.09	0.008
HL0108-0005	5	5	10	18	0.10	0.01
HL0108-0006	6	6	12	21	0.15	0.023
HL0108-0008	8	8	16	28	0.25	0.052
HL0108-0010	10	10	20	35	0.50	0.095
HL0108-0012	12	12	25	42	0.60	0.19
HL0108-0016	16	16	32	56	1.10	0.44
HL0108-0020	20	20	40	70	1.60	0.80
HL0108-0022	22	22	44	77	2.50	1.20
HL0108-0025	25	25	50	88	3.00	1.72
HL0108-0028	28	28	56	98	3.50	2.50
HL0108-0032	32	32	64	112	4.50	3.70

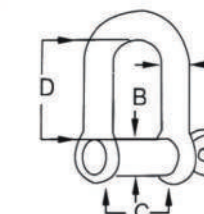

WIRE ROPE CLIP JIS TYPE

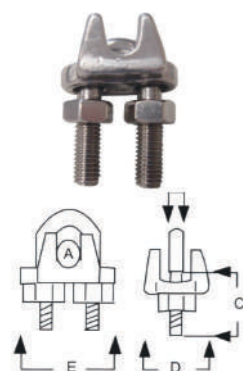

Code No.	A (mm)	B (mm)	C (mm)	D (mm)	E (mm)	WT (Kg)
HL0303-0002	2	3	10	14	14	0.008
HL0303-0003	3	4	12	16	17	0.017
HL0303-0004	4	4	13	18	19	0.020
HL0303-0005	5	6	15	20	24	0.035
HL0303-0006	6	6	15	22	28	0.047
HL0303-0008	8	8	20	28	34	0.085
HL0303-0010	10	10	28	35	45	0.164
HL0303-0012	12	12	35	39	51	0.250
HL0303-0014	14	12	40	45	53	0.290
HL0303-0016	16	14	45	48	60	0.400
HL0303-0018	18	14	50	53	62	0.450

TURNBUCKLE FRAME TYPE

Code No.	A (mm)	B (mm)	C (mm)	D (mm)	E (mm)	WLL (T)	WT (Kg)
HL0233-0005	5	70	130	8	9	0.10	0.08
HL0233-0006	6	100	160	10	9	0.25	0.11
HL0233-0008	8	125	200	12	10	0.35	0.21
HL0233-0010	10	150	245	16	11	0.50	0.34
HL0233-0012	12	200	300	20	14	1.00	0.65
HL0233-0016	16	250	400	22	18	1.50	1.30
HL0233-0020	20	300	480	28	20	2.30	2.50
HL0233-0022	22	325	520	33	22	3.20	3.93
HL0233-0025	25	350	560	35	26	4.50	5.89

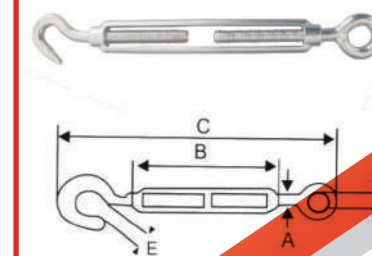



WIRE ROPE CLIP

CLIP

DIN741 CLIP

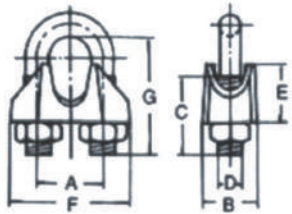

Size		Dimensions (mm)							100/WT(Kg)
mm	in	A	B	C	D	E	F	G	
3	1/8	9	10	12	4	10	21	16	1.4
5	3/16	11	11	13	5	10	23	19	1.5
6.5	1/4	13	12	15	5	11	26	23	2.1
8	5/16	16	14	19	6	15	30	28	4.1
10	3/8	19	18	22	8	17	34	34	6.8
11	7/16	20	19	22	8	18	36	36	7.2
13	1/2	24	23	30	10	21	42	45	13
14	9/16	25	23	30	10	22	44	47	13.5
16	5/8	29	26	33	12	26	50	51	21
19	3/4	32	29	38	12	30	54	63	28
22	7/8	37	33	44	14	34	61	71	40
26	1	41	35	45	14	37	65	81	44
30	1 1/8	48	37	50	16	43	74	94	66
34	1 1/4	52	42	55	16	50	80	104	85
40	1 1/2	58	45	60	16	55	88	124	104

GALV MALLEABLE WIRE ROPE CLIP TYPE A

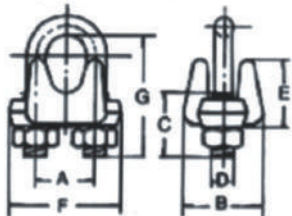

Size (in)	Dimensions (mm)							100/WT(Kg)
	A	B	C	D	E	F	G	
6	12	17	14	5	14	23	24	2.5
8	15	21	16	6	17	28	30	4.5
10	19	28	20	8	21	38	37	9
12	24	34	25	10	27	45	47	18
15	29	40	30	12	32	52	56	28
20	36	47	36	14	38	62	70	47
22	40	52	39	16	43	69	77	62
25	43	56	44	18	50	76	85	85
28	48	62	48	20	57	85	95	120
32	55	67	51	22	61	93	108	157
40	64	81	62	24	73	111	120	261
45	72	88	70	27	85	123	137	363
50	80	95	80	30	95	135	154	480

Forged Wire Rope Clip U.S G-450 Clip

Rope Size (in.)	Weight Per 100(lbs)	Dimensions(in)							
		A	B	C	D	E	F	G	H
*1/8	6	0.22	0.72	0.44	0.47	0.37	0.38	0.81	0.99
*3/16	10	0.25	0.97	0.56	0.59	0.50	0.44	0.94	1.18
1/4	19	0.31	1.03	0.50	0.75	0.66	0.56	1.19	1.43
5/16	28	0.38	1.38	0.75	0.88	0.73	0.69	1.31	1.66
3/8	48	0.44	1.50	0.75	1.00	0.91	0.75	1.63	1.94
7/16	78	0.50	1.88	1.00	1.19	1.13	0.88	1.91	2.28
1/2	80	0.50	1.88	1.00	1.19	1.13	0.88	1.91	2.28
9/16	109	0.56	2.25	1.25	1.31	1.34	0.94	2.06	2.50
5/8	110	0.56	2.25	1.25	1.31	1.34	0.94	2.06	2.50
3/4	142	0.62	2.75	1.44	1.50	1.39	1.06	2.25	2.84
7/8	212	0.75	3.12	1.62	1.75	1.58	1.25	2.44	3.16
1	252	0.75	3.50	1.81	1.88	1.77	1.25	2.63	3.47
1-1/8	283	0.75	3.88	2.00	2.00	1.91	1.25	2.81	3.59
1-1/4	438	0.88	4.44	2.22	2.31	2.17	1.44	3.13	4.13
1-3/8	442	0.88	4.44	2.22	2.38	2.31	1.44	3.13	4.19
1-1/2	544	0.88	4.94	2.38	2.59	2.44	1.44	3.41	4.44
1-5/8	704	1.00	5.31	2.62	2.75	2.66	1.63	3.63	4.75
1-3/4	934	1.13	5.75	2.75	3.06	2.92	1.81	3.81	5.24
2	1300	1.25	6.44	3.00	3.38	3.28	2.00	4.44	5.88
2-1/4	1600	1.25	7.13	3.19	3.88	3.19	2.00	4.56	6.38
2-1/2	1900	1.25	7.69	3.44	4.13	3.69	2.00	4.05	6.63
**2-3/4	2300	1.25	8.31	3.56	4.38	4.88	2.00	5.00	6.88
3	3100	1.50	9.19	3.88	4.75	4.44	2.38	5.31	7.61
**3-1/2	4000	1.50	10.75	4.50	5.50	6.00	2.38	6.19	8.38



Model :G-450

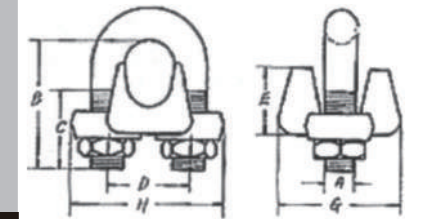

ART. NO	SLEEVE CODE	A (mm)	B (mm)	W (mm)	L (mm)	N. W (Kg) (PER 1000PCS)
DIN 0101	1	1.2	2.4	0.65	5	0.94
DIN 0102	1.5	1.7	3.4	0.75	6	0.21
DIN 0103	2	2.2	4.4	0.85	7	0.375
DIN 0104	2.5	2.7	5.4	1.05	9	0.499
DIN 0105	3	3.3	6.6	1.25	11	0.843
DIN 0106	3.5	3.8	7.6	1.5	13	1.32
DIN 0107	4	4.4	8.8	1.7	14	1.81
DIN 0108	4.5	4.9	9.8	1.9	16	2.61
DIN 0109	5	5.5	11.0	2.1	18	3.57
DIN 0110	6	6.6	13.2	2.5	21	5.86
DIN 0111	6.5	7.2	14.4	2.7	23	7.55
DIN 0112	7	7.8	15.6	2.9	25	9.5
DIN 0113	8	8.8	17.6	3.3	28	13.7
DIN 0114	9	9.9	19.8	3.7	32	19.8
DIN 0115	10	10.9	21.8	4.1	35	26.4
DIN 0116	11	12.1	24.2	4.5	39	35.8
DIN 0117	12	13.2	26.4	4.9	42	45.8
DIN 0118	13	14.2	28.4	5.4	46	59.7
DIN 0119	14	15.3	30.6	5.8	49	73.5
DIN 0120	16	17.5	35.0	6.7	56	111
DIN 0121	18	19.6	39.2	7.6	63	156
DIN 0122	20	21.7	43.4	8.4	70	217
DIN 0123	22	24.3	48.6	9.2	77	292
DIN 0124	24	26.4	52.8	10.0	84	376
DIN 0125	26	28.5	57.0	10.9	91	481
DIN 0126	28	31.0	62.0	11.7	98	603
DIN 0127	30	33.1	66.2	12.5	105	739
DIN 0128	32	35.2	70.4	13.4	112	897
DIN 0129	34	37.8	75.6	14.2	119	1077
DIN 0130	36	39.8	79.6	15.0	126	1275
DIN 0131	38	41.9	83.8	15.8	133	1503
DIN 0132	40	44.0	88.0	16.6	140	1734
DIN 0133	42	46.2	92.4	17.5	147	2024
DIN 0134	44	48.4	96.8	18.3	154	2314
DIN 0135	46	50.6	101.2	19.2	161	2662
DIN 0136	48	52.8	105.6	20.0	168	3010
DIN 0137	50	55.0	110.0	20.8	175	3412
DIN 0138	52	57.2	114.4	21.6	182	3813
DIN 0139	54	59.4	118.8	22.5	189	4293
DIN 0140	56	61.6	123.2	23.3	196	4772
DIN 0141	58	63.8	127.6	24.2	203	5326
DIN 0142	60	66.0	132.0	25.0	210	5880

Aluminium Ferrules



Model :DIN3093

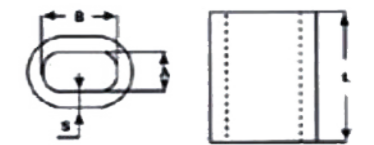



THIMBLES FOR STEEL WIRE ROPE

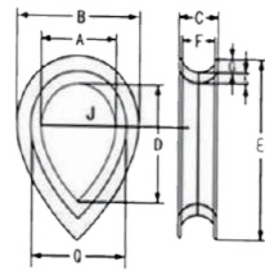

Model : BS464

Product Code	Rope Dia (in)	A	B	Dimensions(in)		E	F	G	K	Q	Weight Each (Kg/pc)
BS464 0601	5/16"	22.2	38	12.7	33.4	52	7.9	4	4	30.1	0.077
BS464 0602	3/8"	25.4	47.6	14.3	38	64	10.3	6.3	4.8	35	0.1
BS464 0603	7/16"	28.6	52	17.5	41.3	73	12.7	7.9	4.8	38	0.107
BS464 0604	1/2"	31.7	53.8	20.6	44.5	79.4	14.3	7.9	5.5	42.9	0.17
BS464 0605	9/16"	31.7	58.8	20.6	44.5	79.4	14.3	7.9	5.5	42.9	0.189
BS464 0606	5/8"	41.3	74.5	22.2	58.8	95.8	15.9	8.7	7.9	56	0.3
BS464 0607	3/4"	50.8	92	28.6	73	124	20.6	11.1	9.5	69.8	0.6
BS464 0608	7/8"	56	102	31.7	82.5	133	22.2	12.7	9.5	76.2	0.69
BS464 0609	1	69.8	119	35	108	162	27	14.3	10.3	90.5	1.15
BS464 0610	1.18	76.2	133	38	112	178	28.6	15.9	12.7	102	1.4
BS464 0611	1.14	95	152	41.3	133	197	33.4	15.9	12.7	121	1.5
BS464 0612	8.13	105	175	47.6	152	228	38	19	15.9	137	2.5
BS464 0614	11.2	114	197	52	165	254	41.3	23.8	17.5	149	3.75
BS464 0615	8.15	114	197	58.6	165	254	42.9	23.8	17.5	149	3.91
BS464 0616	4.13	127	228	56	178	286	50.8	25.4	25.4	178	6.67
BS464 0617	8.17	133	248	66.6	190	317	60.4	28.6	28.6	190	8.42
BS464 0618	2	140	257	69.8	203	330	64	28.6	28.6	197	9.98

Wedge Socket

SIZE (mm)	WEGHT (KN)	B.L.L (KN)	B (mm)	D (H10) (mm)	A (mm)	R (mm)	PIN	Weight (Kg)
6	10	43	29	16	90	16	2x20	0.56
8	10	51	31	18	100	25	2x20	0.77
10	15	71	38	20	120	25	2x25	1.01
12	20	100	44	25	155	30	2x25	1.77
14	25	118.5	51	30	185	35	2x25	3.02
16	30	161.3	60	34	195	42	3x30	4.6
18	35	184	64	36	195	44	3x30	5.35
20	50	249.6	72	38	220	50	3x30	7.9
22	55	285.3	76	40	240	52	4x50	10.8
24	65	327	83	50	260	60	4x50	18.9
26	75	373.6	92	55	280	65	4x50	17.2
28	95	487.6	97	55	305	70	4x50	19.5
32	120	600	110	65	360	77	5x60	32.9
36	155	780	122	70	390	85	5x60	43
40	200	984	145	75	470	90	5x60	55

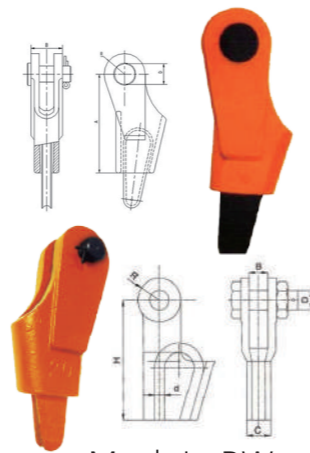

Model : RW



EYE SCREW

Eye Screw Din580 Finish:Bright or Galvanized

Side d	WLL(T)	WLL(T)	Dimensions(mm)							Weight % (Kg)
			d1	d2	d3	b	e	h	k	
M6*	0.07	0.05	17	28	16	13	6	17	6	5
M8*	0.14	0.095	20	36	20	15	6	18	8	6
M10*	0.23	0.17	25	45	25	18	8	22	10	11
M12	0.34	0.24	30	54	30	22	10	26	12	18
M14*	0.49	0.34	35	63	35	28	12	30	14	28.5
M16*	0.7	0.50	35	63	35	28	12	30	14	28
M20	1.2	0.83	40	72	40	30	12	35	16	45
M22*	1.5	1.05	45	81	45	35	14	40	18	67
M24	1.8	1.27	50	90	50	38	16	45	20	87
M27*	2.5	1.65	50	90	50	38	18	45	20	88
M30	3.6	2.60	65	108	60	45	18	55	24	166
M33*	4.3	3.20	65	108	60	45	22	55	24	172
M36	5.1	3.70	75	126	70	55	22	65	28	265
M39*	6.1	4.30	75	126	70	55	26	65	28	280
M42	7.0	5.00	85	144	80	65	30	75	32	403
M45*	8.0	5.50	85	144	80	65	30	75	32	425
M48	8.6	6.10	100	166	90	70	35	85	38	638
M52*	9.9	7.30	100	166	90	70	35	85	38	660
M56	11.5	8.30	110	184	100	80	38	95	42	880
M64	16.0	11.0	120	206	110	90	42	100	48	1240

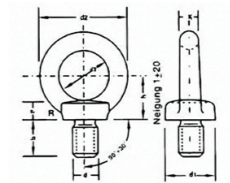

Model : DIN580

Ring-Nut Din582 Finish:Bright or Galvanized

Side d	WLL(T)	WLL(T)	Dimensions(mm)						Weight % (Kg)
			d1	d2	d3	e	h	k	
M6*	-	-	20	36	20	8.5	18	8	4.9
M8*	0.14	0.095	20	36	20	8.5	18	8	5
M10*	0.23	0.17	25	45	25	10	22	10	9
M12	0.34	0.24	30	54	30	11	26	12	16
M16	0.7	0.5	35	63	35	13	30	14	24
M20	1.2	0.83	40	72	40	16	35	16	36
M22*	1.5	1.05	45	81	45	18	40	18	58
M24	1.8	1.27	50	90	50	20	45	20	72
M27*	2.5	1.65	50	90	50	20	45	20	70
M30	3.6	2.6	65	108	60	25	55	24	132
M33*	4.3	3.2	65	108	60	25	55	24	130
M36	5.1	3.7	75	126	70	30	65	28	208
M39*	6.1	4.3	75	126	70	30	65	28	202
M42	7	5	85	144	80	35	75	32	311
M45*	8	5.5	85	144	80	35	75	32	304
M48	8.6	6.1	100	166	90	40	85	38	502
M52*	9.9	7.3	100	166	90	40	85	38	495
M56	11.5	8.3	110	184	100	45	95	42	669
M64	16	11	120	206	110	50	105	48	930

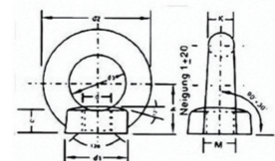

Model : DIN582